

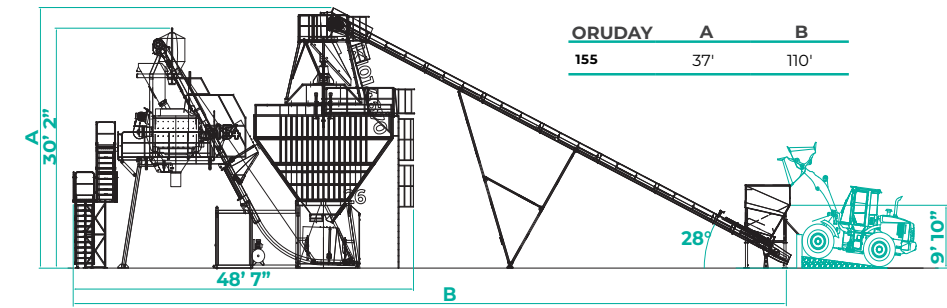

ORUONEDAY LOADED WITH CONVEYOR

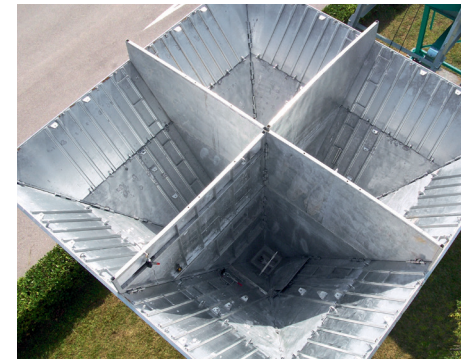

ORUONEDAY LOADED WITH PAYLOADER

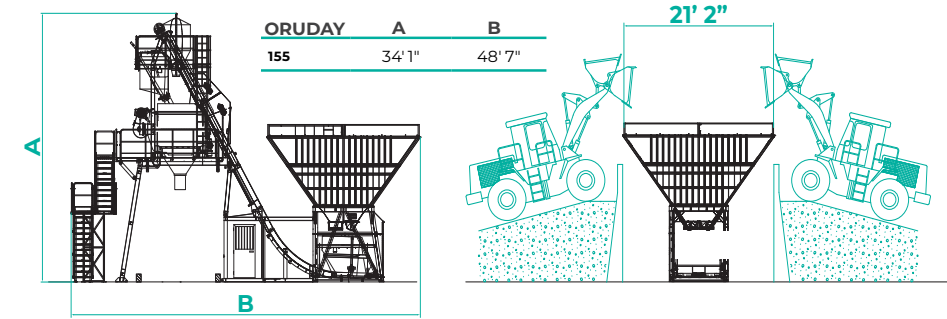

There are 2 options with the ORU OneDay batch plant. With either a stacker belt or load directly with a wheel loader. Either way, the MD mixer can deliver up to 155 cubic yards per hour.

The OneDay utilizes a skip to load the aggregate from the galvanized 4 bins. While the mixer is mixing the skip is loading to ensure that the material arrives in time once the mixer is ready.

This is a great option when needing to enclose a plant due to environmental reasons.

TECHNICAL SPECIFICATIONS		ORUONEDAY 155
Hourly Production	yd ³ /hr	155
Batch Capacity	yd ³	3.3
Power Required	HP	174
Twin Shaft Mixer	model	ORUMD 3750/2500
Cement Weighing Hopper	tons	2.3
Water Weighing Hopper	gal	185
Weighing System	type	load cells
Aggregate Storage Volume	yd ³	128 - 460
Management Unit	model	HPS 2100V