

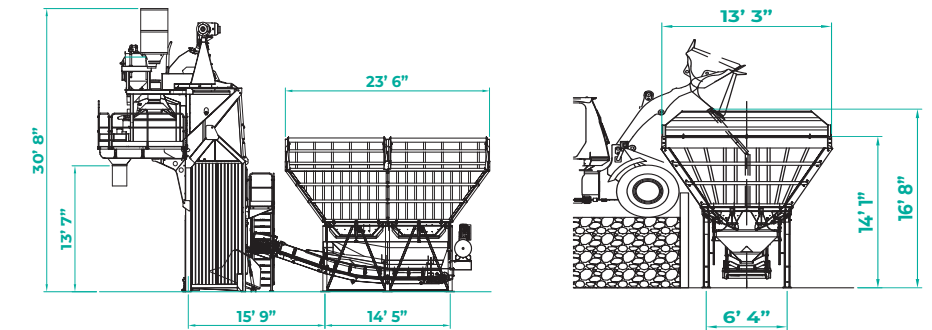

**ORUMULTIS55 WITH B BELTUP**



Easy to setup and compact. This is a great option when you need concrete but. It is especially useful when you are in a confined area when the use of readymix trucks is not practical. The Multis 75 is also equally adept for pre-cast applications.

The Belt-Up configuration has 4 galvanized bins that can be loaded with a wheel loader eliminating the need for stacker belts. The skip loads the aggregates vertically which reduces the footprint of the plant. This is especially useful in tight and confined spaces.

The MS planetary mixer ensures that the concrete that is produced is of the highest quality.

**TECHNICAL SPECIFICATIONS**

		<b>ORUMULTIS 75</b>
Hourly Production	yd <sup>3</sup> /hr	75
Batch Capacity	yd <sup>3</sup>	1.3
Power Required	hp	91
Mixer	model	ORUMS 1500/1000A
Cement Weighing Hopper	tons	1.1
Water Weighing Hopper	gal	106
Weighing System	type	load cells
Aggregate Storage Capacity - S - M -B	yd <sup>3</sup>	26 - 71
Additives System (Recommended)	gal/min	3.4
Management Unit	model	HPS 2100V PLC + PC