



# ORULINK

DRY MOBILE BATCH PLANT



ORULINK 150 WITH LOGIK "B" BINS

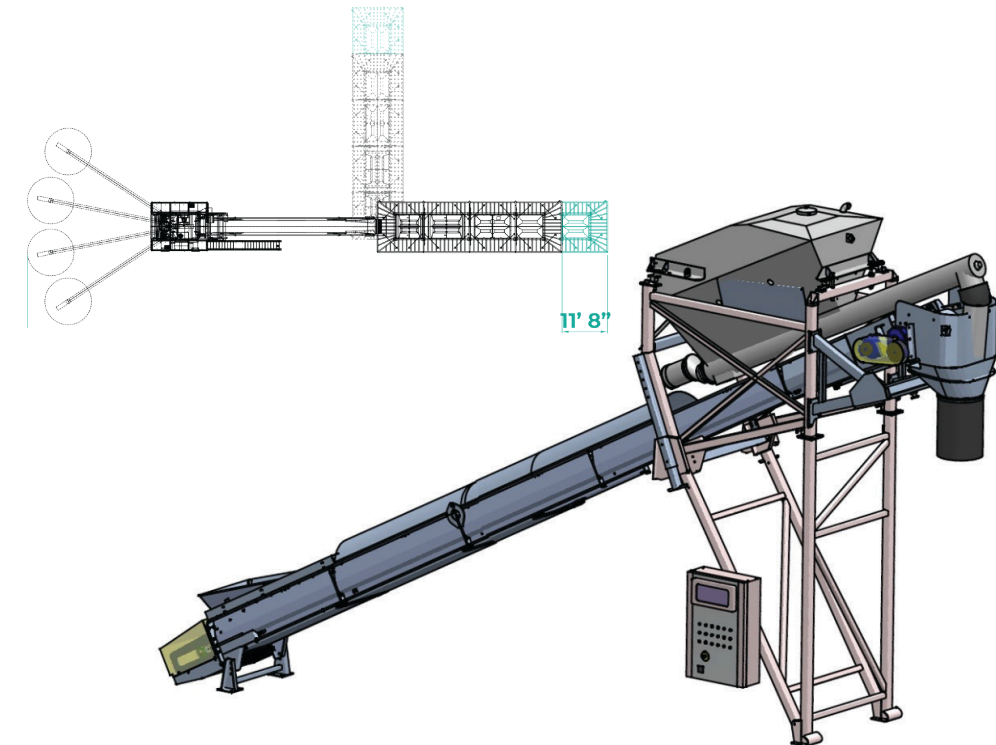
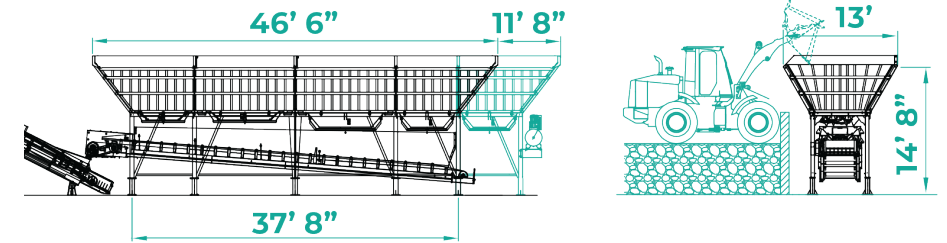

The ORU Link 150 is the ultimate dry plant for when you need more. This plant can produce up to 145 cubic yards per hour of concrete. Mating it with the Logik "B" bins enables the plant to have from 3 to 6 extra large, galvanized storage bins to ensure that the batching never stops.

The easy setup and install makes it ideal to move around to the next project or run it as your main plant. Compact in size and the ability to load from a wheel loader makes for a smaller overall footprint.

Round out the ORU Link 150 by adding silos and additives.

## TECHNICAL SPECIFICATIONS

		ORULINK 150
Hourly Production	yd <sup>3</sup>	145
Power Required	hp	30
Rear Hopper Capacity	yd <sup>3</sup>	11
Loading Conveyor Belt Length	ft	35
Loading Conveyor Belt Width	in	32
Cement Weighing Hopper	tons	3.2
Weighing System	type	load cells
Aggregate Storage Capacity	yd <sup>3</sup>	105 - 157
Management Unit	model	HPS 2100V

[www.imerusa.com](http://www.imerusa.com)