



MIXERS

PUMPS

SAWS

DUMPERS

AERIAL LIFTS



ABOUT **IMER USA**

In the ever-evolving landscape of construction machinery, **IMER USA** stands as a beacon of innovation and reliability. With a legacy spanning decades, the company has consistently pushed the boundaries of engineering excellence, making significant strides in the industry. **IMER's** commitment to quality, advanced technology, and customer satisfaction has established it as a leading name in the construction equipment sector. With 4 distinct divisions, **IMER** provides everything from small - to medium-size construction equipment to full-scale batch plant solutions and ready-mix trucks, as well as a full line of aerial equipment, including scissor and spider lifts.

Innovation at its Core

IMER USA's success story is woven with threads of innovation. The company has been at the forefront of introducing cutting-edge technologies that redefine construction processes, from state-of-the-art concrete mixers, aerial lifts, and earth-moving machines to full-scale batch plants and ready-mix trucks. **IMER USA's** product line is a testament to its unwavering dedication to innovation. By investing in research and development, the company continues to pioneer solutions that enhance efficiency, safety, and precision on construction sites.

Quality That Speaks Volumes

One of **IMER USA's** standout features is its unwavering commitment to quality. Every piece of machinery that bears the **IMER** logo is synonymous with durability and performance. Rigorous quality control measures ensure that customers receive products that not only meet but exceed industry standards. This dedication to quality has earned **IMER** the trust of construction professionals globally, making it their preferred choice when it comes to equipment that stands the test of time.

Customer-Centric Approach

At the heart of **IMER USA's** success is its customer-centric approach. The company understands the unique needs of its clients and tailors its products and services accordingly. Whether it's providing personalized training sessions, offering prompt technical support, or customizing equipment to suit specific project requirements, **IMER** goes the extra mile to ensure customer satisfaction. This focus on building lasting relationships has fostered a loyal customer base and a strong reputation in the industry.

Thank you for your interest in **IMER**,

The **IMER USA** Team

TABLE OF CONTENTS



MIXERS

BARREL MULTI-MIXERS.....	5
Wheelman II.....	5
Minuteman II.....	5
Multi-Mix 350.....	6
Workman II 250 & 350.....	7
MORTAR MIXERS.....	8
HSM 6, 8 & 12.....	8
SPIN SERIES MIXERS.....	9
Spin 15 A.....	9
Spin 30 Plus.....	9
VERTICAL SHAFT MIXERS.....	10
Mix-All 60.....	10
Mix 120 Plus.....	11
Mix 200.....	12
Mix 360.....	13
Mix 750.....	14

SAWS

COMBICUT SERIES.....	16
Combicut 200 & 250 VA.....	16
Combicut 250 / 1000 & 1500.....	17
Combicut 350 iPower.....	18
MASONRY SERIES.....	19
Masonry 350 Smart.....	19
Masonry 750 Plus.....	20
FLOOR SAWS.....	21
Terra Cut 500.....	21

SAW BLADES

IMER SAW BLADES.....	22
----------------------	----

GROUT PUMPS

CONTINUOUS MIXER / PUMPS.....	26
Koine 3.1.....	26
Koine DUAL.....	28
PROGRESSIVE CAVITY PUMPS.....	30
Mighty Small 50 PLUS.....	30
Step-Up 120 Three-Phase.....	32
Prestige 300.....	34

CONCRETE PUMPS

PISTON PUMPS.....	36
Booster 20.....	36
GERRIS 800.....	39

MINI DUMPERS

Tracker 811.....	41
Tracker 1215.....	42
Tracker 1624.....	44
Tracker 2833.....	46
Tracker 4150.....	47

SKID STEERS

SL-3730.....	48
--------------	----

SPECIALTY PRODUCTS

IMER Clean and Shield.....	45
----------------------------	----

ELECTRIC POWERED SLAB SCISSOR LIFTS

MICRO SCISSORS.....	54
IM 3113.....	54
IM 3116.....	54
FULL SIZE SCISSORS.....	56
IM 3219 E.....	56
IM 3224 E.....	56
IM 3534 E.....	58
IM 3540 E.....	58
IM 4740 E.....	60
IM 4746 E.....	60

ROUGH TERRAIN SCISSOR LIFTS

IM 7043 RT.....	64
IM 8747 RT.....	66
IM 8756 RT.....	66

TRACK DRIVEN ARTICULATED & TELESCOPIC LIFTS

SERIES IM R 23 DA.....	70
SERIES IM R 19.....	72
SERIES IM R 15 DA.....	74
SERIES IM R 13 T.....	76

TELEMATICS

IMERVIEW.....	78
---------------	----

WARRANTY

Warranty Information.....	79
---------------------------	----



MIXERS



MORTAR, STUCCO, GROUT, CONCRETE

Multi-Mixers

Mortar Mixers

Continuous Mixers

Vertical Shaft Mixers

IMER is known world-wide for its mixers due to its vast experience from small, portable mixers to its large batch plants. No matter how large or small the project may be, IMER has a solution to help you maximize your time and ROI. Designed to handle the most impossible of mix designs and aggregate types.

The IMER Multi-Mixers, Mortar Mixers, Spin Series Continuous Mixers, and Vertical Shaft mixers are ideal for efficiently and quickly mixing all types of pre-blended materials from dry pack consistency to a fluid grout. Mortar one day, stucco the next. Tackle high-strength grouts the day after, or make them all in one day without any waste.

In addition, IMER Mixers are designed to work with IMER mixer/pump spray machines and grout pumps - the perfect companions for semi-automatic production.



WHEELMAN II & MINUTEMAN II

COMPACT, PORTABLE MULTI-MIXER

BELTLESS GEAR-DRIVEN PORTABLE MIXER FOR MORTAR, STUCCO, GROUT, OR CONCRETE

The Wheelman II and Minuteman II are the highest performing, most reliable, affordable small portable mixers today. Both are easy to transport and assemble, and both are built to tackle all types of projects and materials, such as mortar, stucco, grout, concrete. Choose either poly or steel drum models.



✓
1/2 HP, 120V motor with gearbox drive

✓
Choose either metal or poly drum. Both drums are interchangeable

✓
Pneumatic wheels for easy transport

OPTIONAL 355° SWIVEL STAND

Wheelman stand is easy to dump, and it swivels a full 355°. Item # 1105490



Technical specifications

POWERED by **HONDA**

	WHEELMAN II Gas	WHEELMAN II Elec.	MINUTEMAN II
Model # steel drum	n/a	1105422	1126608
Model # poly drum	1105426	1105421	1126632
Drum capacity	5 cu ft	5 cu ft	5 cu ft
Batch output	2.5 cu ft	2.5 cu ft	3 cu ft
Motor	Honda 3 hp	1/2 hp 120v/6amp	1/2 hp 120v/6amp
Drum diameter	24 in	24 in	24 in
Discharge outlet height	8 in / 21 w/stand	8 in / 21 w/stand	21 in
Wheel size	14 in pneumatic tires	14 in pneumatic tires	10 in wheels
Weight	115 lbs.	101 lbs.	101 lbs.
Width**	26 in (26 in)	26 in (26 in)	26 in (26 in)
Length**	46 in (29 in)	46 in (29 in)	52 in (26 in)
Height**	36 in (27-1/2 in)	36 in (27-1/2 in)	57 in (27 in)

(*) Warning: Cancer and Reproductive Harm - <https://www.p65warnings.ca.gov>
 (**) Operating Dimensions (palletized)

MULTI-MIX 350 SYNTESI

PORTABLE MULTI-MIXER

THE MULTI-MIX 350 IS IMER'S NEW PORTABLE, NON-TOWABLE MIXER

Mortar, stucco, grout, or concrete - big brother to The Wheelman II and Minuteman II mixers. Designed and built to mix large batches in a portable 120V traditional concrete mixer. The transmission system inserted in the arm and the convenient worm screw tilting system makes it noiseless and lightweight, and at the same time, sturdy and reliable.



NOISE LEVEL
<72 DB

Technical specifications

MULTI-MIX 350

Model #	1105802
Drum capacity	12 cu ft
Batch output	9.5 cu ft
Motor	2 hp, 120V electric
Batch output	2.5 cu ft
Motor rating	Honda 3 hp
Wheel diameter	15 in
Weight	385 lbs.
Width	32-1/2 in
Length	63-1/4" in
Height	63 in



PERFORMANCE MIXING BLADES

The Multi-Mix 350 blades are heavy-duty construction, welded and screwed for added strength and a consistent mix.



QUIET GEARBOX

Direct drive gearbox to the drum, no more external drive gears. This drive system is whisper quiet and is sealed for life. Little maintenance is ever required.

(*) Operating Dimensions (palletized)

WORKMAN II 250 & 350

TOWABLE BARREL MIXER

MIX PERFECT MORTAR AND CONCRETE

The Workman II 250 and 350 Multi-mixers are the contractor's choice for heavy-duty mixers. IMER's steel drum towable mixers are easy to use, easy to maintain, durable, reliable, and long-lasting. Available in a full range of sizes and engine and motor configurations. Mix up to 15, 80 pound bags of concrete per batch, 10 bags for the 250 model.

- ✓ "Posi- lock" auto locks / unlocks when activated
- ✓ Box steel frame is very strong and reliable
- ✓ Comes with a tow hitch ball adapter
- ✓ Forklift pockets enable easy transport



QUIET GEARBOX

Direct drive gearbox to the drum, no more external drive gears. This drive system is whisper quiet and is sealed for life. Little maintenance is ever required.



✓ Impact-resistant fenders keep their shape

✓ Torsion bar suspension for easy towing

✓ Comes complete with spare tire



END DUMP 350 VERSION

Perfect for utility work to load and dump without the need to disconnect from the tow vehicle



Technical specifications

POWERED by **HONDA**

	WORKMAN II 250	WORKMAN II 350	WORKMAN II 350ED
Model # gas	1105850	1105855	1105838
Model # electric 120V	1105842	1105862	n/a
Model # electric 240V	1105843	1105863	n/a
Model # less power	1105851	1105856	n/a
Drum capacity	9 cu ft	12 cu ft	12 cu ft
Batch output	6 cu ft	9.5 cu ft	9.5 cu ft
Motor gas	Honda GX 160, 5.5 hp	Honda GX 160, 5.5 hp	Honda GX 160, 5.5 hp
Motor electric	120V / 240V 1.5 hp	120V / 240V 1.5 hp	n/a
Drum diameter	29-1/2 in	34-3/4 in	34-3/4 in
Discharge outlet height	27-3/4 in	26.-1/2 in	26.-1/2 in
Weight	525 lbs.	650 lbs.	650 lbs.
Width**	50 (50) in	50 (50) in	50 (50) in
Length**	72 (80) in	76-1/2 (86) in	76-1/2 (86) in
Height**	55 (68) in	56 (72) in	56 (72) in

(*) Warning: Cancer and Reproductive Harm - <https://www.p65warnings.ca.gov>
 (**) Operating Dimensions (palletized)

HSM 6, 8, & 12

TOWABLE MORTAR MIXER

POWERFUL, TOWABLE, MORTAR MIXER

The HSM 6 (6CF), HSM 8 (8CF), and HSM 12 (12CF) towable mortar mixers utilize a gearbox design to transfer the power efficiently to the mixing paddles. Honda GX engines or 120 / 240V industrial electric motors deliver the power to produce perfect mortar, stucco or grout efficiently.

✓ The optional spiral mixing blades with heavy-duty design, allowing a mix that's up to 30% faster

✓ Pillow blocks mounted externally keep the shaft spinning smoothly

✓ Locking handle ensures that the mix won't dump on you unexpectedly

✓ Equipped with a 2" ball hitch as standard. Pintle loop available upon request

✓ Large grab handle makes dumping the load easy and safe

✓ Extra large safety grate comes standard

✓ Choose from Honda GX-390 11.7 hp or Leeson 1.5 hp 120 V

✓ Optional torsion bar axle available upon request



POWERED by **HONDA**

Technical specifications

	HSM 6	HSM 8	HSM 12
Model # gas / steel (poly)	1130061 (1130063)	1130081 (1130083)	1130121
Model # elec. / steel (poly)	1130062 (1130064)	1130082 (1130084)	1130122
Bag capacity	2 - 2.5	2.5 - 3	3.5 - 4
Batch output	6 cu ft	8 cu ft	12 cu ft
Motor gas	Honda GX 160, 5.5 hp	Honda GX 240, 8 hp	Honda GX 390 13 hp
Motor electric	120V / 240V 1.5 hp	120V / 240V 1.5 hp	240V 5 hp
Tire size	5.3 x 12 in	5.3 x 12 in	B78 - 13 in
Charging height	57-1/2 in	59-3/4 in	58 in
Weight	500 lbs.	650 lbs.	1,200 lbs.
Width	45 in	45 in	52-1/2 in
Length (with tow bar)	75 (94-1/2) in	73 (92-3/4) in	84 (104-1/2) in
Height	55 in	57-1/2 in	56-1/2 in



QUIET GEARBOX
The enclosed gearbox provides a quieter mixer that produces less heat and gear wear, meaning your machine runs more efficiently and longer.

SPIN 15 & SPIN 30 PLUS

CONTINUOUS MIXER FOR PREMIXED MATERIALS

INDUSTRY CHANGING, HIGH-OUTPUT CONTINUOUS MIXERS

Ideal for quickly and efficiently mixing; preblended plasters, mortars, stuccos, grouts, self-leveling underlayments, preblended conventional floor-screeds. Team the continuous mixer with an IMER spray and grout pump for semi-automatic production.



WATER FLOW METER

Allows the water level to be set for easy setup when using the same material.



WATER PUMP

Standard on the Spin 30 and optional on the Spin 15. Used to boost the water flow or siphon from a tank.

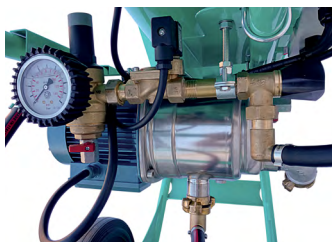

Technical specifications

	SPIN 15A	SPIN 30 PLUS
Model #	1106340	1106152
Hopper / tank capacity	250 lbs.	500 lbs.
Mixing performance	.5 cu ft / min	1 cu ft / min
Mixer/paddle speed	280 rpm	280 rpm
Motor power rate	1.75 hp	3 hp (220v single-phase)
Standard power rate	optional	yes
Standard dust grate	yes	yes
Weight (with packaging)	187 lbs. (196 lbs.)	281 lbs. (292 lbs.)
Dimensions w/l/h	27.5 in x 54 in x 46 in	25 in x 71 in x 46 in
Box dimensions	31.5 in x 23.25 in x 32.5 in	N/A

MIX-ALL 60

PORTABLE PADDLE MIXER

THE LIGHTWEIGHT, QUIET, PORTABLE YET POWERFUL

Mix-All 60 saves time and reduces labor costs. The 120V motor gearbox drivetrain is both powerful, and quiet. The unique paddles allow it to quickly and thoroughly mix mortar, stucco, thin set, dry pack mortar, epoxy, plaster, and more. It's also used for mixing rubber materials.



5 PACK OF BUCKETS Model #1193968



ALTERNATIVE MIXING PADDLE Model #3205587

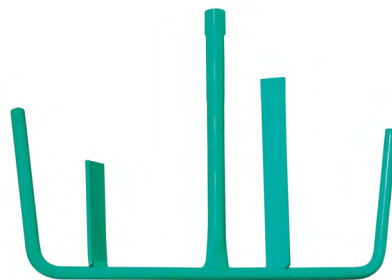

Technical specifications

	MIX-ALL 60
Model #	1193988
Drum capacity	14 gal
Batch output	12 gal / 50 lbs. bag
Drum diameter	24 in
Maximum aggregate size	3/8 in
Paddle speed	55 rpm
Motor rating	3/4 hp, 120v
Current draw	10 amps
Noise	70 dB(A)
Machine weight (boxed)	66 lbs. (70 lbs.)
Width (boxed)	23 in (23 in)
Length (boxed)	25 in (24 1/2 in)
Height (boxed)	31 - 1/4 in (18 in)

MIX 120 PLUS MORTARMAN

PORTABLE VERTICAL SHAFT PADDLE MIXER

VERTICAL SHAFT MIXER WITH A POWERFUL MIXING ACTION

The Mix 120 Plus can make a wheelbarrow of mortar, stucco, grout, or dry pack cement every 3 minutes. Vertical shaft mixers deliver so much mixing torque that the Mix 120 Plus can out produce a two-bag towable mixer when making dry pack cement. Team the continuous mixer with an IMER spray and grout pump for semi-automatic production.

2 HP, 120V motor
with gearbox drive
with reverse

Transport wheels
to help maneuver
the mixer where
you need it



OUTLET

Discharge of material is very controlled. Whether you need a trowel, a bucket, or a wheelbarrow full of material, it's all there.



OPEN GRATE OR IDUST® GRATE

When ordering, choose from the iDUST® grate or the open grate. Shown with dust grate here.

WHY VERTICAL SHAFT MIXERS?

The paddles are always in the mix, thoroughly and quickly mixing materials without air entrapment. Shown here with rubber paddles (item # 1107618).



Technical specifications

	MIX 120 PLUS
Model # (iDUST Grate)	1194302
Model # (open grate)	1194304
Drum capacity	4.25 cu ft
Batch output	3 cu ft
Drum diameter	30 in
Maximum aggregate size	3/8 in
Paddle speed	38 rpm
Motor rating	2 hp, 120V
Current draw	15 amps
Noise	70 dB(A)
Machine weight (boxed)	286 lbs. (310 lbs.)
Width (boxed)	30 in (31 in)
Length (boxed)	33 in (35 in)
Height (boxed)	50 in (38 in)

MIX 200 FP

PORTABLE VERTICAL SHAFT PADDLE MIXER

THE MIX 200 FP (FIREPROOFING) POWERED BY 120V, 1.5HP

Using our mixer technology found in our Mix series we combined the need to mix 2 bags of fireproofing per batch on 120V. The Mix 200 FP is a non towable, portable mixer that can fit over sprayer pumps to discharge into the hopper. The extra large opening of the iDUST® grate makes it possible to load the mixer and still keep the dust under control.

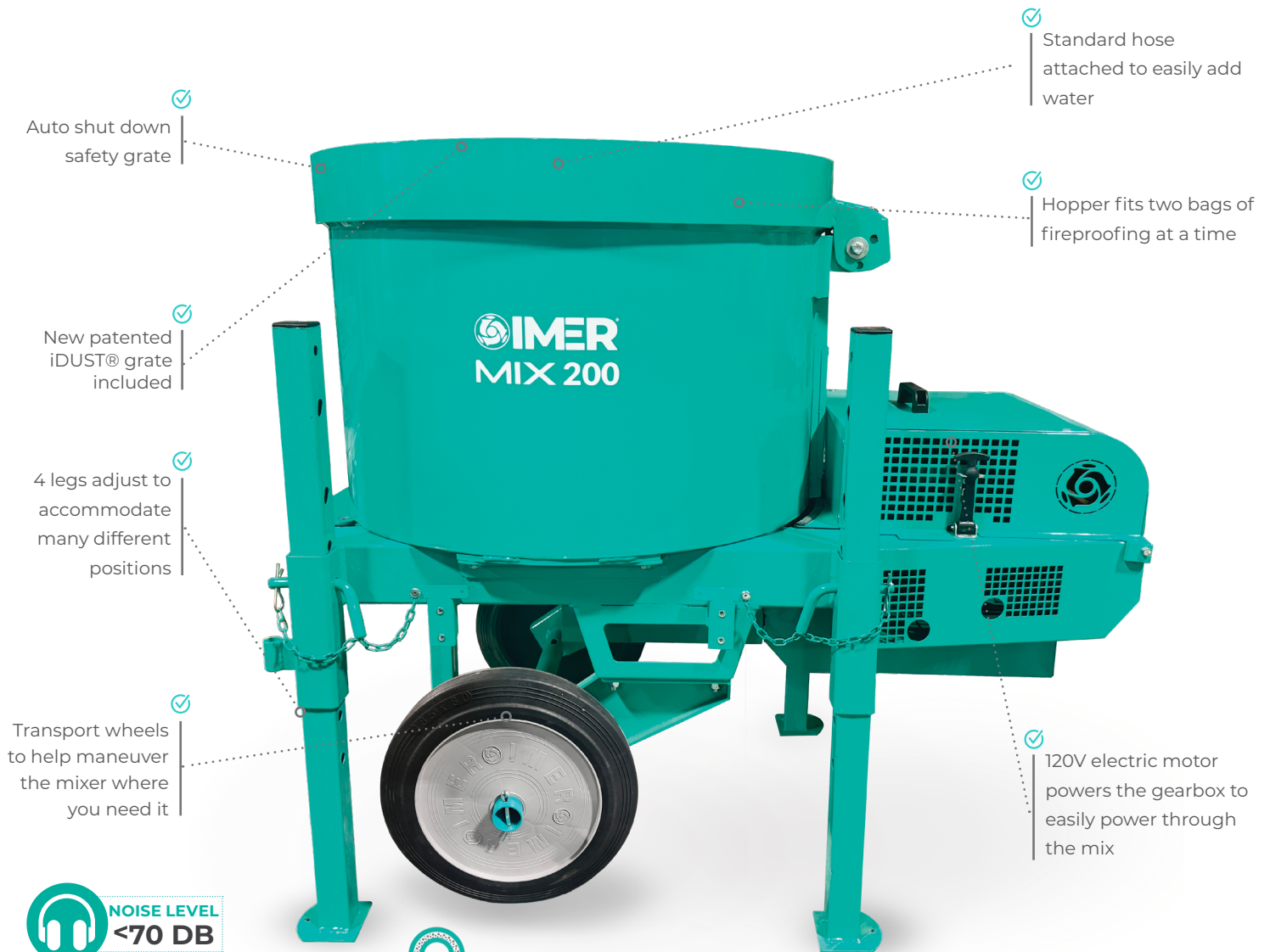

Technical specifications

	MIX 200 FP
Model #	1195163
Drum capacity	5 cu ft
Mixing performance	2 Bags Fireproofing
Drum diameter	32 in
Paddle speed	32 rpm
Machine weight	573 lbs.
Wheel dimensions	15 in
Engine/motor power	1.5 HP, 120V 60 Hz
Discharge height	22/27/32 in
Loading height	90 (86) in
Machine Weight	573 lbs.
Width (boxed)	30in (40 in)
Length (boxed)	54 in (49 in)
Height (boxed)	50 in (36 in)



DUST GRATE INCLUDED
The Mix 200 dust grate has been made bigger to accommodate fireproofing sized bags.

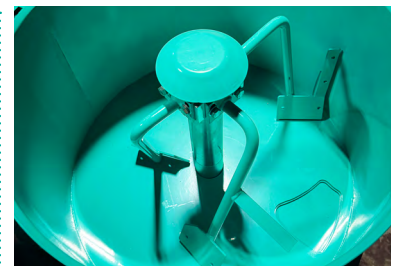

SPECIAL PADDLES
The Mix 200 paddle kit is designed specifically for fireproofing, giving more shear than standard paddles.

MIX 360 PLUS MORTAR MAN

TOWABLE VERTICAL SHAFT PADDLE MIXER

THE MIX 360 OFFERS UNPARALLELED PRODUCTION AND JOBSITE / PLANT SAFETY

Vertical shaft mixers use the principles of concrete batch plant design, which allows for the paddles to rotate through the mix rather than lift and drop it as conventional mortar mixers do. The Mix 360 vertical shaft towable mixer easily mixes very low slump materials like dry pack mortar and refractory cement, as well as UHPC.



Technical specifications

	MIX 360 PLUS
Model # (Plus)	1194662
Model # (Plus Gas)	1194661
Drum capacity	12 cu ft
Batch output*	9 cu ft
Maximum aggregate size	3/8 in
Discharge outlet height: max/min	30/18 in
Pneumatic wheels	18 in
Weight: electric / gas	787/794 lbs.
Electric motor	240v, 5hp, 1ø
Gas engine*	Honda GXV390 11hp
Width (packaged)	44 in (50 in)
Length (packaged)	59 in (80 in)
Height (packaged)	58 in (56 in)

RELIABILITY

The paddle systems are powered by monster gearboxes which were developed in our batch plant division.

Mixing loads with 3/8 in aggregates is no problem.



PRODUCTION

Listening, studying, and testing have lead to drum and paddle design changes that vastly improve batch output.

Why not have Mini Batch Plant (MBP) production for the cost of a mortar mixer?

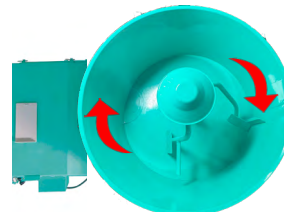

INDUSTRIAL ELECTRIC MOTOR

The motors used in the MIX 360 are industrial-duty electric motors. The motors can operate continuously and easily mix stiff, dry materials.



(*) Materials can influence the batch output (**) Warning: Cancer and Reproductive Harm <https://www.p65warnings.ca.gov>

MIX 750 MORTARMAN

TOWABLE VERTICAL SHAFT PADDLE MIXER

PRODUCE 18 CUBIC FEET OF MUD EVERY THREE TO FOUR MINUTES WITH THE MIX 750

The Mix 750 is the perfect partner for busy precast mixing operations, and on bridge and highway jobs. The discharge system is easy to open and close and protected from being hit by a mud bucket or forklift. The safety grate is hinged, making access immediate. The Mix 750 is Mini-Batch Plant production for a fraction of the cost. These mixers develop vast amounts of mixing power, far more than any horizontal shaft mortar mixer. The ability to mix refractory mud or stiff, dry materials is unparalleled in the industry.

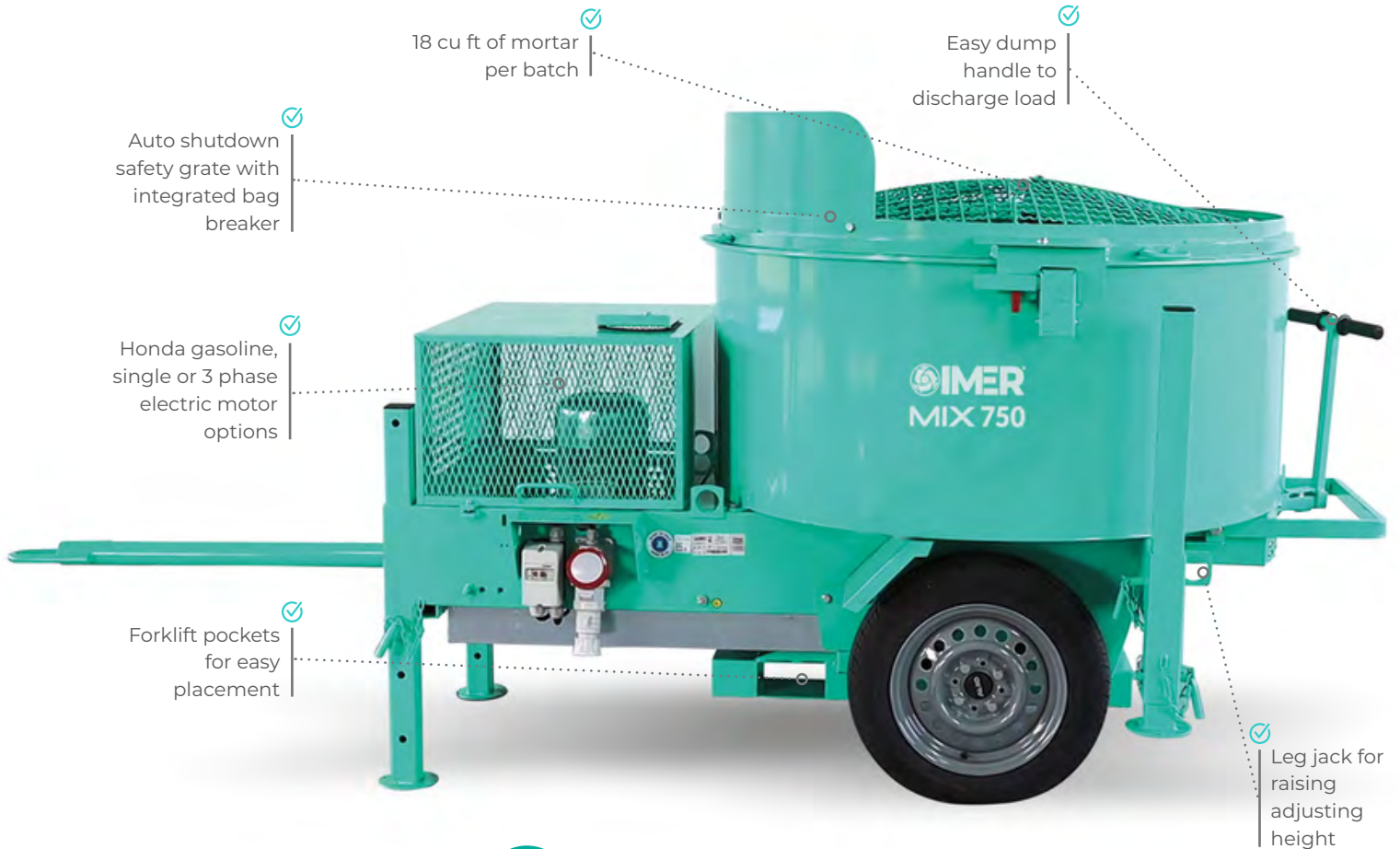

POWERED by
HONDA



Technical specifications

	MIX 750
Model # (240V, 5 HP, Single-Phase)	1194644
Model # (208V, 7.5 HP, 3 Phase)	1194645
Model # (480V, 7.5 HP, 3 Phase)	1194646
Model # (Gas, 13 HP Honda GX)	1194648
Model # (No motor)	1194640
Drum capacity	22 cu ft
Batch output	18 cu ft
Drum diameter	52 in
Maximum aggregate size	3/8 in
Discharge outlet height: max/min	29 in / 23 in
Pneumatic wheels	22 in
Weight	1,588 lbs.
Width (palletized)	63 in (64 in)
Length (palletized)	90 in (86 in)
Height (palletized)	62 in (64 in)



SET UP

The stability legs slide outward to accommodate a wide variety of mud pans. They can also be adjusted up or down depending upon the desired discharge height.

These extra wide stability legs are standard on the Mix 750.



INDUSTRIAL ELECTRIC MOTOR

The motors used in the MIX 750 are industrial-duty electric motors available in a wide range of voltage, single-phase or three-phase. The motors can operate continuously and easily mix stiff, dry materials.

(*) Materials can influence the batch output (**). Warning: Cancer and Reproductive Harm - <https://www.p65warnings.ca.gov>

(***) Operating Dimensions (palletized)

COMBICUT & MASONRY SAWS

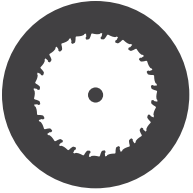

*TILE, STONE, BRICK, BLOCK,
SLAB SAWS & BLADES*

Overhead Rail Saws

Stone & Slab Saws

Brick & Block Saws

When you need a saw that can handle it all, look no further than IMER's Combicut and Masonry series of saws. Made to be accurate, powerful and light, and comfortable in any environment, Combicut saws are used in fabrication shops to outdoor patio construction sites, small and large tile installations.

Stone and slabs keep getting bigger and bigger. High horsepower and a sturdy frame allow the Combi-cut series to make the cuts that other saws could only dream of. Use for precast, stone, ceramic, porcelain, brick and pavers.

The Masonry Series saws were designed for cutting bricks, blocks, and stones. Use the Masonry series for cutting of larger, bulkier materials when you need depth of cut.



COMBICUT 200/250 VA

TILE STONE AND PORCELAIN SAWS

ACCURATE, LIGHTWEIGHT OVERHEAD RAIL SAW

The Combicut 200 and 250 are ideal for those smaller jobs with tile sizes up to 31" overall. Weighing less than 75 pounds makes this easy to transport but big on features. Comes with side table, protractor, folding stand and general purpose blade. Use for cutting accurate miters. Comes completely assembled out of the box, only the stand requires 2 bolts.



PLUNGE CUTS

Plunge cuts are smooth and precise as the cast aluminum cutting head pivots on a sealed bushing. "L" cuts for door jams are now quick n' simple.

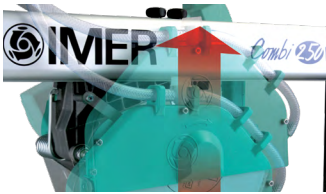

Included side table for extra work space

High impact removable poly water pan with baffles

TILE CLAMP FOR ACCURACY

The tile clamping system is an accessory that attaches to all Combicut Series saws. Clamp down tiles and use the overhead laser to guarantee a smooth, thorough, and accurate cut. Item # 1188157



ACCURATE ANGLED CUTS

When 45 degree cuts are needed, just tilt the travel beam. Simple and accurate. While the overhead beam design provides a smooth accurate cut.



NOISE LEVEL
<78 DB

Technical specifications

	COMBICUT 200VA	COMBICUT 250VA
Model #	1188084	1188164
Blade diameter	8 in	10 in
Blade shaft diameter	5/8 in	5/8 in
Max. cutting length (w/ plunge cut)	21 in (24 in)	28 in (31 in)
Max. cutting depth	2.75 in	3.75 in
Motor rating	1.75 hp 120 v, 15 amp	1.75 hp 120 v, 15 amp
Blade speed	2800 rpm	2800 rpm
Weight (boxed, includes stand)	48 lbs. (68 lbs.)	72 lbs. (85 lbs.)
Water pan capacity	5 gal	10 gal
Water pump flow	3 gpm	3 gpm
Length* (boxed)	35 in (37 in)	40 in (43 in)
Height* (boxed)	19 in (22 in)	22 in (24 in)
Width* (boxed)	18 in (20 in)	18 in (21 in)

COMBICUT 250 SERIES

TILE STONE AND PORCELAIN SAWS

ACCURATE, CHIP-FREE CUTTING PERFORMANCE

Over the years, porcelain and stone have increased in size as manufacturing has improved to make larger pieces of tile. This has created the need for a saw that can be extremely accurate and long. IMER has kept up with the trend offering a portable saw with a cutting length up to 60 inches.



TILE CLAMP FOR ACCURACY

The tile clamping system is an accessory that attaches to all Combicut Series saws. Clamp down tiles and use the overhead laser to guarantee a smooth, thorough, and accurate cut. Item # 1188157



SIDE TABLE INCLUDED

The side table supports large format tiles.

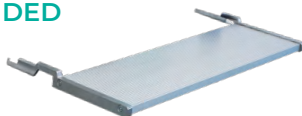

Technical specifications

	250/1000 VA	250/1500 VA
Model #	1188174	1188180
Blade diameter	10 in	10 in
Blade shaft diameter	5/8 in	5/8 in
Max. cutting length (w/ plunge cut)	37 in (40 in)	57 in (60 in)
Max. cutting depth	3.75 in	3.75 in
Motor rating	1.75 hp 120 v, 15 amp	1.75 hp 120 v, 15 amp
Blade speed	2800 rpm	2800 rpm
Weight (boxed, includes stand)	92 lbs. (98 lbs.)	125 lbs. (150 lbs.)
Water pan capacity	12 gal	13 gal
Water pump flow	3 gpm	3 gpm
Length* (boxed)	55 in (58 in)	76 in (77 in)
Height* (boxed)	24 in (26 in)	24 in (26 in)
Width* (boxed)	25 in (27 in)	25 in (27 in)

(* Operating Dimensions (boxed))

COMBICUT 350 iPOWER

TILE STONE AND PORCELAIN SAWS

TILE, STONE & MASONRY SAW FOR PRECISE, LENGTHY CUTS

The 4 HP high-torque motor in the Combicut 350 iPower ensures that cuts are made quickly and accurately. Tile and stone installers, masons, precast fabricators, landscapers, and general contractors worldwide put the Combicut 350 iPower to the test every day.

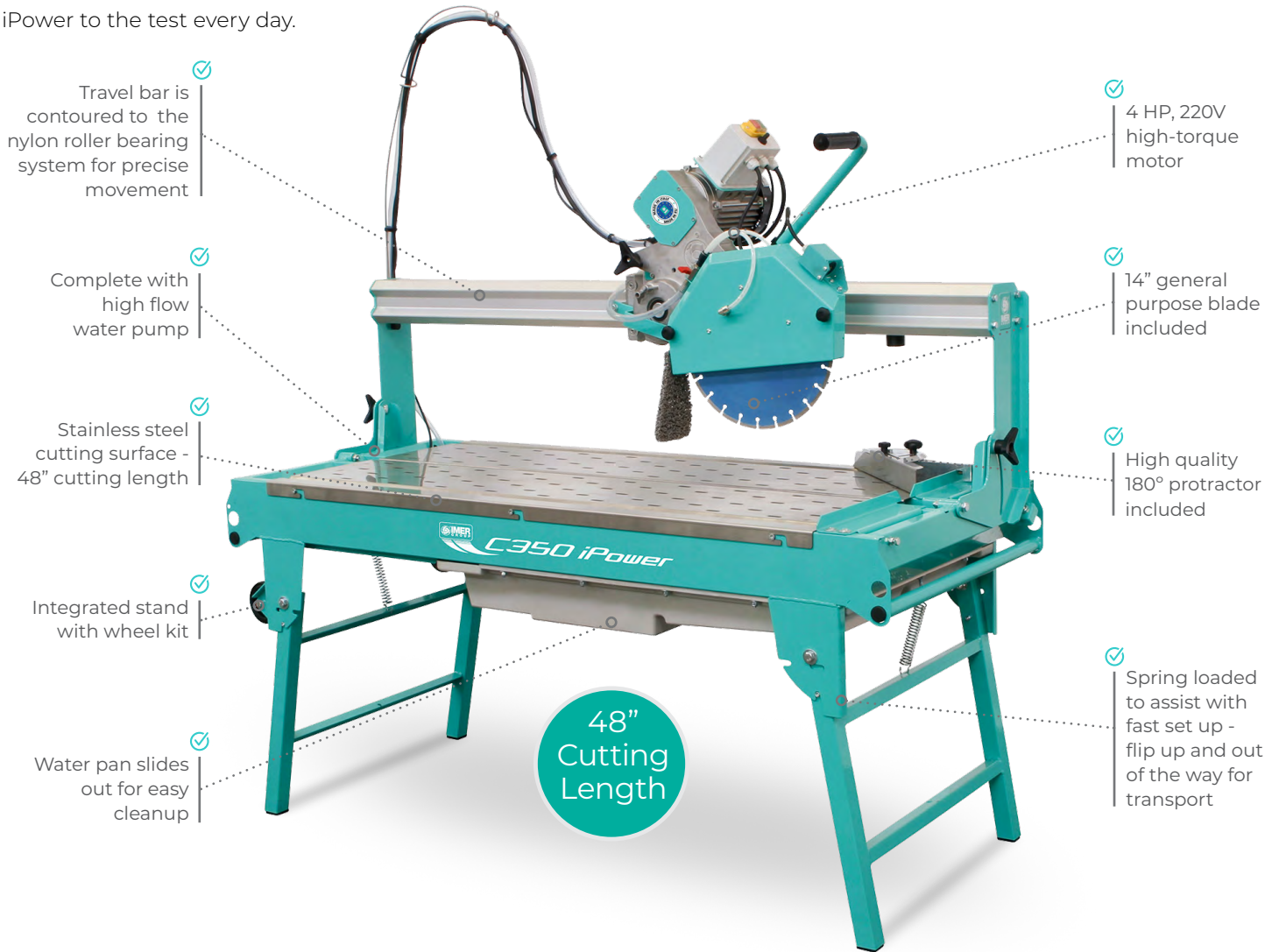

Travel bar is contoured to the nylon roller bearing system for precise movement

4 HP, 220V high-torque motor

Complete with high flow water pump

14" general purpose blade included

Stainless steel cutting surface - 48" cutting length

High quality 180° protractor included

Integrated stand with wheel kit

Spring loaded to assist with fast set up - flip up and out of the way for transport

Water pan slides out for easy cleanup

48" Cutting Length



Technical specifications

350 iPOWER	
Model #	1188931
Blade diameter	14 in
Blade shaft diameter	1 in
Max. cutting length (w/ plunge cut)	41.5 in (47.25 in)
Max. cutting depth	4.75 in / 2.25 in
Motor rating	4 hp 220v, 15 amp
Blade speed	2800 rpm
Weight (boxed, includes stand)	265 lbs. (300 lbs.)
Water pan capacity	9 gal
Water pump flow	--
Length* (boxed)	69 in (70 in)
Height* (boxed)	55.5 in (60.5 in)
Width* (boxed)	30 in (30.5 in)

POWER

The motor in the COMBI 350 iPOWER is a high-torque 4 hp 220V Single-Phase stone and paver eating machine. All this power goes from the motor to the blade via a high tech serpentine belt. No adjustment or maintenance

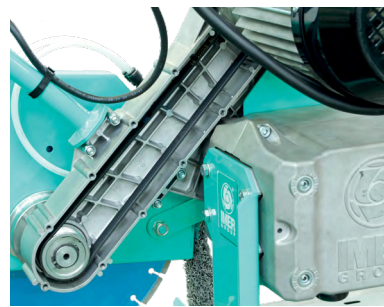

ACCURATE 45° CUTS

When 45 degree cuts are needed, just tilt the travel beam. The overhead beam design provides a smooth accurate cut. Simple and accurate.



(* Operating Dimensions (boxed)

SMART CUT 350

BRICK AND BLOCK SAW

THE BEST SOLUTION FOR CUTTING BRICKS, BLOCKS, PAVING STONES, OR TILE

The biggest cutting table available on a 14" masonry saw. The Smart Cut 350 delivers very accurate cuts up to 30" in length and 4 3/4" deep. The 2 HP motor provides the power required to cut through larger and longer pieces day in and day out.

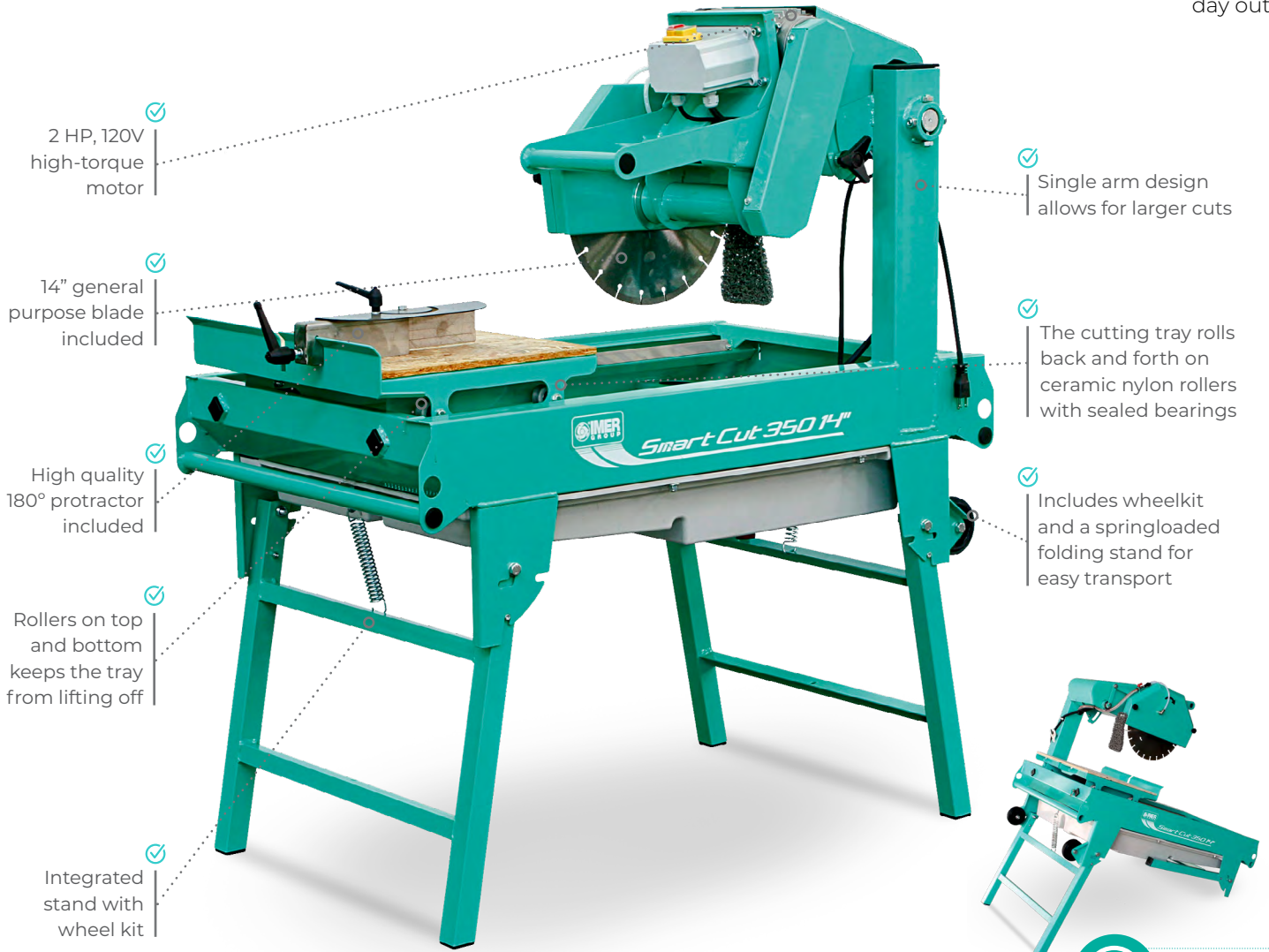

2 HP, 120V high-torque motor

Single arm design allows for larger cuts

14" general purpose blade included

The cutting tray rolls back and forth on ceramic nylon rollers with sealed bearings

High quality 180° protractor included

Includes wheelkit and a springloaded folding stand for easy transport

Rollers on top and bottom keeps the tray from lifting off

Integrated stand with wheel kit



Technical specifications

SMART CUT 350

Model #	1188975
Blade diameter	14 in
Blade shaft diameter	1 in
Max. cutting length (w/ plunge cut)	26 in (30 in)
Max. cutting depth	4.75 in
Motor rating	2 hp, 120v, 15 amps
Blade speed	2850 rpm
Weight (boxed, includes stand)	175 lbs. (215 lbs.)
Water pan capacity	10 gal
Water pump flow	3 gpm
Length* (boxed)	47 in (48 in)
Height* (boxed)	51 in (55 in)
Width* (boxed)	28.5 in (29 in)

(*) Operating Dimensions (boxed)

INNOVATION

The blade guard is lined with sound absorbing material used in the boat building industry, and this greatly reduces noise from the blade. The blade guard may be removed with just two thumb screws – changing blades is fast and easy.



MITER CUT ACCESSORIES

If your work requires you to make 45 degree miter cuts, we have developed an accurate and easy-to-use miter for the Smart Cut 350 and Masonry 750 saws.

Smart Cut 350, Item # 1187640
Masonry 750, Item # 1188870

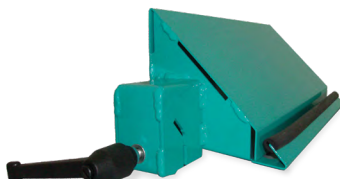

MASONRY 750 PLUS

BLOCK, STONE AND PRECAST SAW

THE ERGONOMIC 30" SAW HANDLES BIG BLOCK AND STONE

The Masonry 750 Plus allows operators to cut 8" and 10" blocks in a single pass – without the added hassle and effort of a foot pedal. The powerful 7.5 hp electric motor combined with the 30" blade delivers 12" of cutting depth. Cut through blocks, pavers, stone and pre-cast concrete products with ease. The frame and cutting tray are hand fabricated using heavy-duty steel, while the ergonomic design allows the operator to transport the saw with little effort.



Technical specifications



MASONRY 750	
Model # (Single-Phase)	1188863
Model # (3 Phase)	1188864
Blade diameter	30 in
Blade shaft diameter	1 in
Max. cutting depth (incl. plunge)	18 in (27 in)
Motor rating	5.5 hp 240v, 1ø or 7.5. hp 240v, 3ø
Blade speed	1700 rpm
Weight (crated)	440 lbs. (495 lbs.)
Water pan capacity	9 gal
Self-priming centrifugal pump	3 gpm
Length* (boxed)	61 in
Height* (boxed)	63 in
Width* (boxed)	33.5 in

(* Operating Dimensions (boxed)

VERSATILITY

Should it be necessary to make a plunge cut just grab the tilt handle and ease the blade into the material. The cutting head pivots on sealed bearings, making plunge cuts is smooth and controlled.

EASE OF USE

The Masonry 750 is designed to make it easier to move the blocks on and off the saw. The lower profile allows the operators to get a lot more done in a day.

QUALITY

The box steel frame is very rigid yet light for a saw of this size. Proven design techniques combined with high-quality steel makes for one powerful machine.



POWER

The 30" blade begins to spin very efficiently as the optional 7.5HP motor is equipped with an electronic soft start system.

PORTABILITY

The wheelkit and the well engineered balance of the saw allow it to be rolled around by one person. Easily handled by a forklift as lift slots are welded into a frame.

TERRA CUT 500

FLOOR SAW

LIGHTWEIGHT, COMPACT, AND EASY TO HANDLE

Designed for cutting large concrete and asphalt surfaces, featuring a patented fast system for handwheel locking/unlocking to maintain cutting depth, double vibration damping system for enhanced operator comfort, patented automatic parking brake linked to blade height, polyethylene water tank with quick joint system, and welded steel chassis for structural rigidity ensuring cutting precision in all conditions.

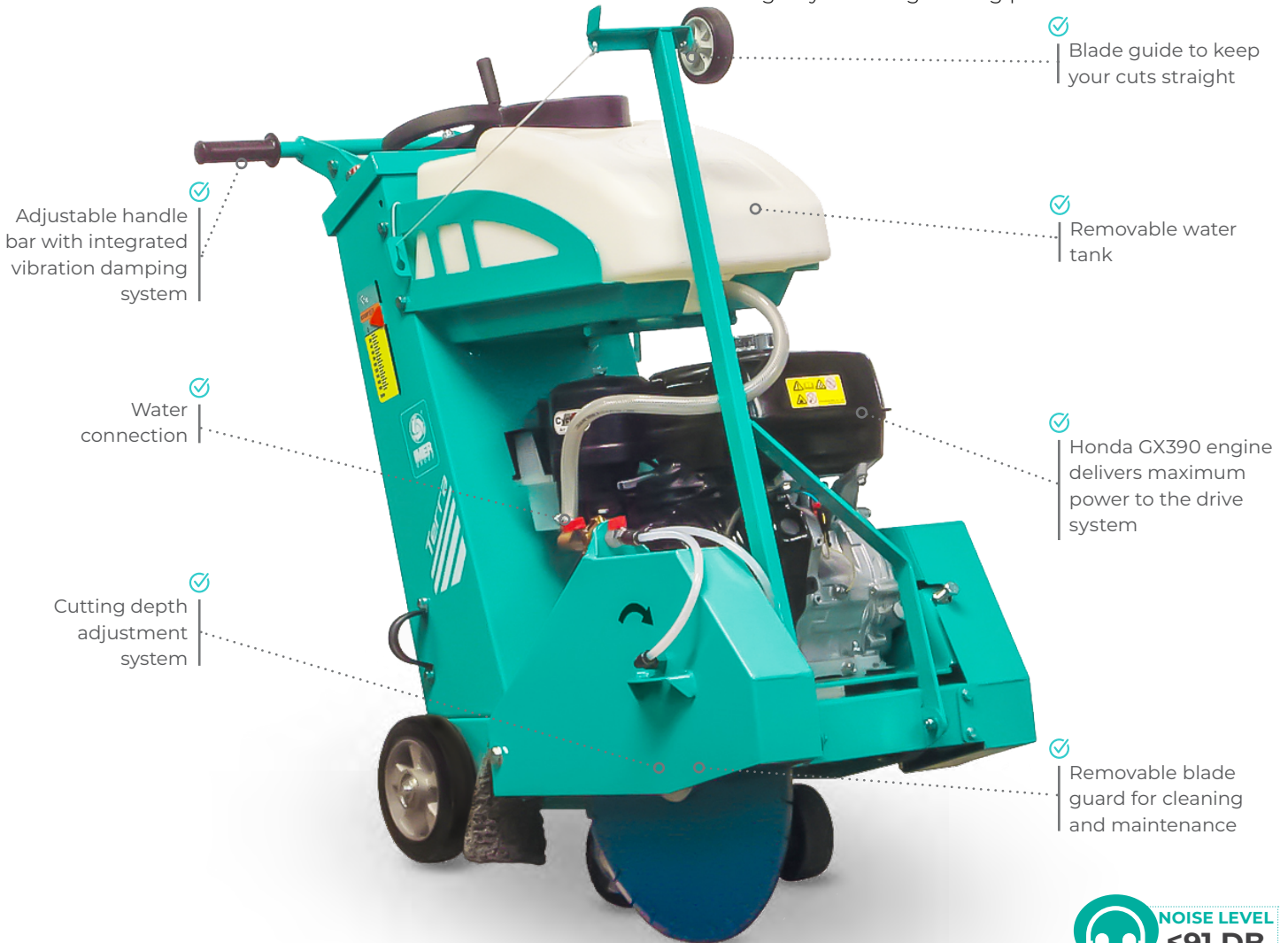

Adjustable handle bar with integrated vibration damping system

Water connection

Cutting depth adjustment system

Blade guide to keep your cuts straight

Removable water tank

Honda GX390 engine delivers maximum power to the drive system

Removable blade guard for cleaning and maintenance



TRANSMISSION BY POLY-V BELT

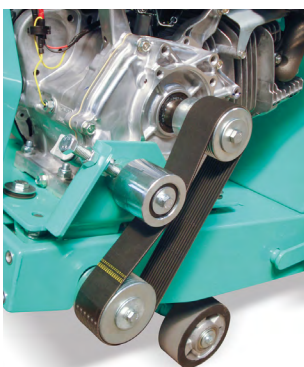

PATENETED FAST SYSTEM FOR LOCKING THE HAND WHEEL



TERRA CUT 500

Model #	1193732
Engine Power	Honda GX390 13 hp
Max engine speed	3,850 rpm
Starting	Manual
Forward drive	Manual
Blade / Bore Diameter	20 in / 1 in
Max cutting depth	7.5"
Max blade peripheral speed	246 ft/sec
Lp in operator's position	91 dB(A)
Machine weight (packed)	287 lbs. (309 lbs.)
Dimensions with mounted blade and lifted rod w/l/h	24 in x 54 in x 48.5 in
Packing dimensions w/l/h	26 in x 47 in x 48 in
Max stackability	2 (h 94.5 in)

SAW BLADES & ACCESSORIES

TILE, STONE, MASONRY, AND HARD MATERIAL



CONTINUOUS RIM TILE BLADES

SIZES: 8" | 10" | 14"

IMER's continuous rim blades are designed to cut Ceramic tile, Porcelain and Stone. Continuous rim blades are best for accurate, chip-free cutting performance, essential for cosmetic appearance.

PART # BLADE

- 1193920 8" x .060 Continuous Rim Porcelain & Hard Materials
- 1193922 10" x .060 Continuous Rim Porcelain & Hard Materials
- 1193924 14" x .090 Continuous Rim Porcelain & Hard Materials



SEGMENTED PREMIUM MASONRY BLADES

SIZES: 10" | 14" | 20" | 30"

IMER's premium segmented blades are designed specifically for abrasive masonry applications such as Block, Brick, Sandstone, and Soft Stone.

PART # BLADE

- 1193932 10" x .110 Segmented Premium Masonry
- 1193934 14" x .125 Segmented Premium Masonry
- 1193938 20" x .155 Segmented Premium Masonry*
- 1193913 30" x .165 Full Segmented Premium Masonry
- 1193957 30" x .165 Segmented Premium Masonry

**Conversion kit required*

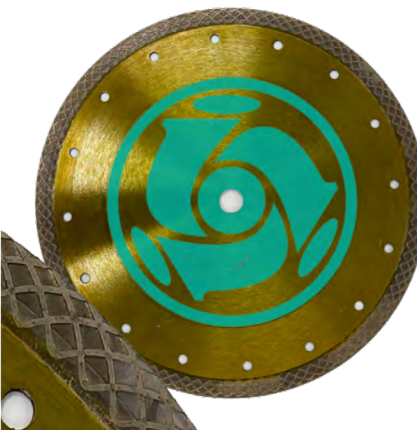

TGM-X SERIES BLADE - CONTINUOUS RIM BLADES

SIZES: 10"

IMER's continuous rim blades are designed to cut Ceramic tile, Porcelain and Stone. Continuous rim blades are best for accurate, chip-free cutting performance, essential for cosmetic appearance.

PART # BLADE

- 1193962 10" x .060 Continuous Rim Porcelain & Hand Materials

**Conversion kit required*

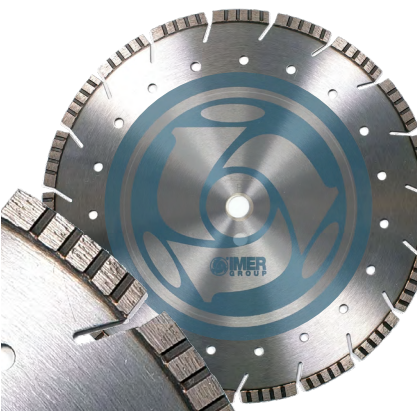

CONCRETE TURBO BLADES

SIZES: 10" | 14" | 20"

IMER's hard masonry turbo blades are designed to handle a multitude of applications starting with Concrete, Block, Brick, Paver Brick, Hard Brick, Masonry, Natural Stone, Refractory Material, Artificial Stone, Sandstone, Soft Stone, Stone.

PART # BLADE

- 1193942 10" x .110 Concrete Turbo with Teardrop Gullets
- 1193944 14" x .125 Concrete Turbo with Gullets
- 1193948 20" x .160 Concrete Turbo with Teardrop Gullets*

**Conversion kit required*

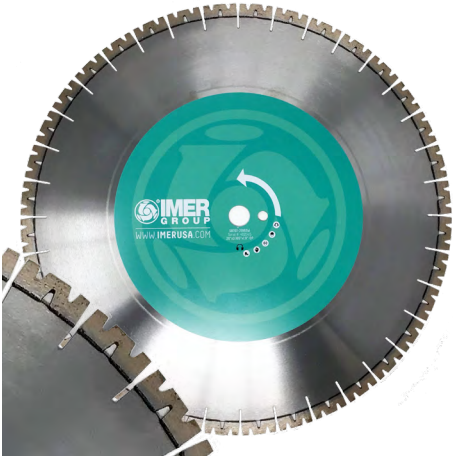

STONE / HARD APPLICATION PREMIUM BLADES

SIZES: 14" | 20" | 30"

IMER's premium diamond blades are built to tackle Block, Brick, Paver Brick, Hard Brick, Masonry, Natural Stone, Refractory Material, Artificial Stone, Sandstone, Soft Stone, Stone. The silent core on the 14" reduces noise.

PART # BLADE

- 1193954 14" x .125 Silent Core for Stone
- 1193956 20" x .165 Stone Cutting Blade*
- 1193958 30" x .165 Stone Cutting Blade
- 1193941 30" x .170 Premium Stone Cutting Blade

*Conversion kit required



CONCRETE PREMIUM BLADE

SIZE: 20"

Concrete Blade for IMER Terra 500 Road Saw

PART # BLADE

- 1193921 20" Premium diamond blade for concrete



ASPHALT / GREEN CONCRETE PREMIUM BLADE

SIZE: 20"

Asphalt / Green Concrete Blade for IMER Terra 500 Road Saw

PART # BLADE

- 1193925 20" Premium diamond blade for Asphalt

PUMP SERIES

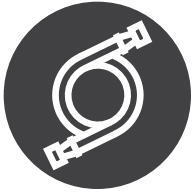

MORTAR, STUCCO, GROUT & CONCRETE

Continuous Pumps

Progressive Cavity Pumps

Piston Pumps

Contractors prefer the reliability, quality, and versatility of IMER's family of pumps. Our proven history and experience in the construction industry throughout the world offer contractors security and unmatched productivity for every project requiring pumping, no matter the size of the project or size of the aggregate used.

IMER offers a wide variety of pumps and a wide range of accessories, all specifically designed and fully engineered to handle a multitude of applications providing your operation versatility and more opportunity to use the pumps daily, increasing your ROI.

Pumping of grouts, self-leveling underlayments, spraying fireproofing, mortar, and stucco setup, low volume shotcrete is just the beginning of the applications IMER pumps were engineered to tackle - and to outperform competitive pumps that only handle one type of pumping application.

Trust the brand with years of experience, engineering excellence, and superior quality.

Trust the brand that contractors prefer.

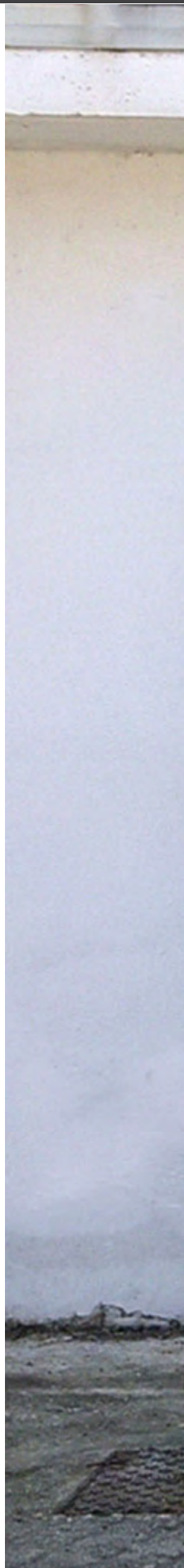



IMER
KOINE
DUAL

KOINE 3.1

CONTINUOUS MIXER / PUMP: CONTINUOUS PUMP FOR PREBLENDED CEMENTITIOUS MATERIALS

CONTINUOUS OPERATION WITH THE EXTRA BENEFIT OF WET OR DRY MODE

The Koine 3.1 is designed to be a continuous pump for feeding bags of dry material such as underlayment, mortar or grouts. But when you need to mix the material with lots of additives which require longer mixing times then switch to wet mode, use a separate mixer such as the Mix 120 and pour it into the hopper to use it as just a pump. This gives the flexibility and versatility to be used for any application. Rinse out the hopper when finished.



Self-priming water pump with stainless steel housing and brass impeller

Store all your accessories in this handy toolbox. Never lose pieces

Use in wet or dry mode depending on your needs

Add the optional compressor to mix and spray 16 bags of fireproofing per hour

Includes adjustable D8 - 1.5 rotor / stator complete with turbo mixer and pressure gauge

Clean out the hoses fast and effortlessly

Single-phase 3 HP motor with "turbo boost" to 5 HP

Inverter technology balances the power and monitors the electricity for maximum performance

6 speed settings deliver up to 120, 50lbs. bags per hour

100% duty cycle motors can run all day long



TURBO MIXER

The turbo mixer provides increased shear and blending of the material before it enters the hoses













Technical specifications

KOINE 3.1	
Model # (5 HP, Single-Phase)	1106351
Power supply	240/60Hz, single-phase
Max installed power	4.5 hp
Mixer motor power	2.9 hp
Electric pump motor power	0.6 hp
Electric compressor	1 - 8.8 KW-l/min
Dry mode material flow rate	1/4 - 3/5 cu ft/min
Wet mode material flow rate	.08 - 3/5 cu ft/min
Hopper volume	2.65 cu ft
Loading height	39"
Sound pressure level	< 76 dB
Dimensions w/l/h	26 in x 41.7 in x 59 in
Complete package weight	350.5 lbs.
Packing size w/l/h	31.5 in x 63 in x 67 in
Weight of the packed machine	507 lbs.

KOINE 3.1 APPLICATIONS

✓ Required ✓ Optional

Product / Part #	Pumping of grouts, self-leveling underlayments	Spraying fireproofing	Spraying mortar, stucco base coat (1/8" or more of build-up)	Spraying waterproofing, stucco, finish coat
 Dual-diaphragm compressor Part # 1107637		✓	✓	✓
 52' x 13 mm Air hose w/ Geka - Part # 1107532 33' x 13 mm Air hose w/ Geka - Part # 1107531		✓	✓	✓
 Mortar, stucco, and fireproofing gun kit Part # 1107005 (pg. 37 for details)		✓	✓	✓
 Stucco and fine coatings gun kit Part # 1107010 (pg. 37 for details)	✓	✓	✓	✓
 D5 - 2.5 Rotor - Part # 1107085 (requires manifold - part # 3223416)	✓	✓	✓	✓
 D5 - 2.5 Stator - Part # 1107084 (requires manifold - part # 3223416)	✓	✓	✓	✓
 D8 - 1.5 Rotor - Part # 1107031 (requires manifold - part # 3223416)	✓	✓	✓	✓
 D8 - 1.5 Stator - Part # 1107030 (requires manifold - part # 3223416)	✓	✓	✓	✓
 Manifold for D Series stators Part # 3223416	✓			
 5' Overhead wand Part # 1107549	✓	✓	✓	✓

STANDARD EQUIPMENT



STANDARD ROTOR / STATOR
D8 - 1.5 Rotor with tab Part # 1107029

- Turbo mixer kit with material delivery pressure gauge
- Control panel w/ exclusive IMER 6-speed inverter
- Self-priming water booster pump
- Water system with flow meter and drainage valves
- 66' of power cord
- 66' of water hose Ø 19 mm (3/4")
- 50' of material hose Ø 25 mm (1")
- 35 mm to 25 mm reducer
- Hose cleaning kit with toolbox

CONTROL PANEL SINGLE-PHASE

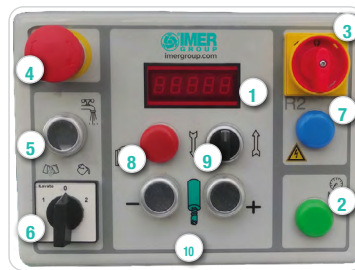

- 1 Smart display panel
- 2 Current indicator light
- 3 ON/OFF switch
- 4 Emergency stop button
- 5 Manual water control
- 6 Water booster pump switch
- 7 Water pressure indicator
- 8 Mixing chamber safety sensor
- 9 Forward/Reverse
- 10 Rotor/stator speed control

KOINE DUAL

CONTINUOUS MIXER / PUMP: HF (HIGH FLOW) CONTINUOUS PUMP FOR PREBLENDED CEMENTITIOUS MATERIALS

CONTINUOUS OPERATION MEANS EFFICIENT AND EFFECTIVE PRODUCTION

The Koine Dual continuous pumps make batching, mixing and pumping easy. Set the water level based on the material requirements and let the pump do the work. Break bags directly into the hopper as the feeding wheel delivers the dry material into the mixing chamber where metered water is introduced. A high shear mixing paddle spins up to 400 RPM on the Koine to whip the material up and discharges into the stator where the rotor creates the pressure to push the material into the hose. A rotor driven impeller ensures that the material is thoroughly mixed before it is placed. The Dual gets its name from having the ability to run on single phase or 3 phase. No more need to decide which one is right for you.



100% duty cycle electric motor is thermally protected from overheating

Run on 3 phase 208V, for full power or 240V single phase up to speed 7 of 8

Self-priming water pump with stainless steel housing and brass impeller

Inverter technology balances the power and allows for 8 speeds on 3 phase as well as soft start

Storage tool box keeps your accessories in one convenient spot

Allows up to 275 bags per hour of underlayment or similar bagged product

Add the optional compressor to spray premixed materials

Control panel has Bluetooth connectivity to the app and the ability to store recipes.

LED backlit display indicates the status of the machine at all times

CONNECT TO THE APP

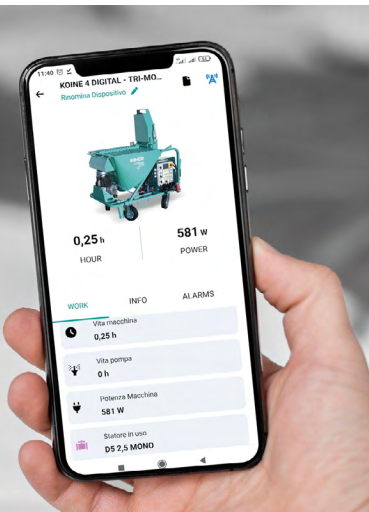

DUST GRATE INCLUDED

Take control of dust. Easily attach Imer's iDUST® dust grate and attach a vacuum, watch the dust pull downward, away from operators.















Technical specifications

KOINE DUAL	
Model #	1106312
Power supply: 3 phase / single phase	208v / 240v
Total machine power	9 hp
Drive motor	7.5 hp
Feed impeller motor	1 hp
Water pump	1 hp
Material flow rate	Up to 140 cu ft/hr
Bags per hour (SLU)	275
Loading height	36 in
Dimensions w/l/h	29 in x 47 in x 62 in
Weight	574 lbs.

KOINE DUAL APPLICATIONS

✓ Required ✓ Optional

Product / Part #	Spraying fireproofing	Spraying mortar, stucco base coat (1/8" or more of build-up)	Spraying waterproofing, stucco, finish coat	Pumping grouts and underlayments
 Dual-diaphragm compressor, single phase Part # 1107637	✓	✓	✓	
 52' x 13 mm Air hose w/ Geka - Part # 1107532 33' x 13 mm Air hose w/ Geka - Part # 1107531	✓	✓	✓	
 Mortar, stucco, and fireproofing gun kit Part # 1107005 (pg. 37 for details)	✓	✓	✓	
 Stucco and fine coatings gun kit Part # 1107010 (pg. 37 for details)		✓	✓	
 R7 - 1.5 Rotor with tab Part # 1107664	✓	✓	✓	✓
 R7 - 1.5 Stator Part # 1107624	✓	✓	✓	✓
 R7 - 2.5 Rotor with tab Part # 1107667	✓	✓	✓	✓
 R7 - 2.5 Stator Part # 1107668	✓	✓	✓	✓
 Mixing paddle for light materials Part # 1107541	✓	✓	✓	
 5' Overhead wand Part # 1107549	✓	✓	✓	
 35 mm - 25 mm Reducer Part # 1107565	✓	✓	✓	
 Spray gun for Koine Part # 1107641		✓		

STANDARD EQUIPMENT



STANDARD ROTOR

R8 - 1.5 Rotor with tab Part # 1107623

STANDARD STATOR

R8 - 1.5 Rotor with tab Part # 1107622

- Turbo mixer kit with material delivery pressure gauge
- Dust grate with vacuum port
- Control panel w/ exclusive IMER 8-speed inverter
- Self-priming water booster pump
- Water system with flow meter and drainage valves
- 133' of power cord
- 133' of water hose Ø 19 mm (3/4")
- 33' of material hose Ø 35 mm (1-3/8")
- 3 phase to single phase adapter
- Hose cleaning kit with toolbox
- Mixing chamber clean out tool
- Air compressor-ready

CONTROL PANEL DUAL-PHASE

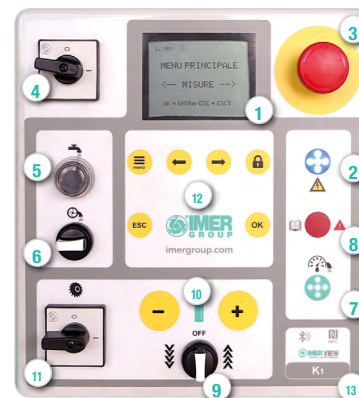

- 1 Smart display panel
- 2 Current indicator light
- 3 Emergency stop button
- 4 ON/OFF switch
- 5 Manual water valve switch
- 6 Water booster pump switch
- 7 Water pressure indicator
- 8 Error code indicator
- 9 Forward/Reverse
- 10 Rotor/stator speed control
- 11 Feeding wheel switch
- 12 Control panel settings
- 13 NFC/Bluetooth connectivity

MIGHTY SMALL 50

PROGRESSIVE CAVITY PUMP: SCREW PUMP FOR PUMPING AND SPRAYING APPLICATIONS

THE MOST VERSATILE SMALL PUMP AND SPRAY MACHINE ON THE MARKET

The Mighty Small 50 EVO & PLUS models are an easily portable multi-purpose pump and spray machine. You may configure the pump with many different accessories depending on the required application. Whether it is pumping grout into forms, on a bridge deck repair project, spraying fireproofing on a high-rise building, or filling blocks with grout, our pumps are the right solution when you have a rigorous pumping application.

Drop in the optional compressor or vibrating grid (pictured) to make it versatile

The hopper height is 25.5" - position a Spin 15 or Mix 120 over the top

Flow rates from 60, 50lbs. bags per hour (Evo) 120, 80lbs. bags per hour (Plus)

IMER's exclusive inverter technology changes speed by modulating the frequency

Electric remote control with 53 ft (16 m) of cable

Maximum versatility: Add the high pressure airless kit to the Plus to spray AVB's and heavy paints and coatings



OPTIONAL COMPRESSOR

Works as a system with pump where controlling the air turns the pump itself on and off.

















Technical specifications

	SMALL 50 EVO	SMALL 50 PLUS
Model #	1106344	1106345
Power	120V	240V
Pump motor	1.75 hp	3 hp, single phase
Max aggregate size	1/4 in	1/4 in
Hopper capacity CF	1.75 cu ft	1.75 cu ft
Loading height	25.5 in	25.5 in
Dimensions w/l/h	20.5 in x 44 in x 25.5 in	20.5 in x 44 in x 25.5 in
Weight	90 lbs.	100 lbs.
Sound pressure level	< 74 dB(A)	< 74 dB(A)

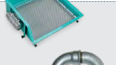
MIGHTY SMALL 50 APPLICATIONS

✓ Required ✓ Optional

Product / Part #	Pumping of grouts, self-leveling underlayments	Spraying fireproofing, repair mortar, stucco base coat	Spraying waterproofing, acrylic stucco, finish coats (1/8" or more of build-up)	Controlled pressure grout injection with pressure regulator	Tuck-pointing and grouting	Airless Spraying
 Dual-diaphragm compressor Part # 1107546		✓	✓			
 52' x 13 mm Air hose w/ Geka - Part # 1107532 33' x 13 mm Air hose w/ Geka - Part # 1107531		✓	✓			
 Mortar, stucco, and fireproofing gun kit Part # 1107005		✓				
 Stucco and fine coatings gun kit Part # 1107010 (pg. 37 for details)			✓			
 Grout injection kit Part # 1107006 (pg. 37 for details)				✓		
 Tuckpointing gun kit with 19 mm reducers Part # 1107504 (pg. 37 for details)					✓	
 33' x 19 mm Material hose Part # 1107529			✓		✓	
 50' x 25 mm Material hose - Part # 1107525 33' x 25 mm Material hose - Part # 1107526 16' x 25 mm Material hose - Part # 1107527	✓	✓	✓		✓	
 5' Overhead wand Part # 1107549		✓				
 Vibrating hopper for tuckpointing Part # 1107015	✓				✓	
 Vibrating screen for bulk sand mixes Part # 1107548	✓				✓	
 Pipe hook for block, form and door jamb filling - Part # 1107570	✓					
 D5 - 2.5 Rotor - Part # 1107085 D5 - 2.5 Stator - Part # 1107084	✓	✓	✓	✓	✓	
 Small 50 Plus - Airless spray kit Part # 1107669						✓

STANDARD EQUIPMENT

MIGHTY SMALL 50

- Rotor and stator D8 - 1.5
- Stainless steel hopper
- Inverter driven control panel
- Electric remote control cable
- Pressure gauge for material pressure
- Accessory toolbox

AIRLESS SPRAY KIT MIGHTY SMALL 50

- Stator 4N13S - Part # 1107220
- Rotor 4N13S - Part # 1107221
- AG19 Gun - Part # 1107643
- Nozzle kit (Nozzles; 617, 619, 531, and 335)
- Filter kit (10 pcs kit green airless filter - Part # 1107650) and 10 pcs kit white airless filter - Part # 1107651)
- Safety sensor, pressure gauge and cable
- 66' Airless hose (1/2") - Part # 1107654
- Gun cleaning kit - Part # 1107658

CONTROL PANEL

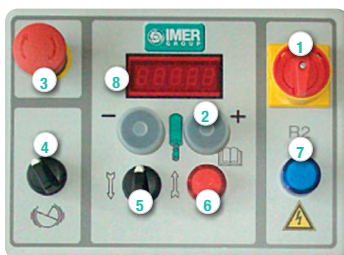

- 1 On/Off switch
- 2 Rotor/stator speed control
- 3 Emergency stop button
- 4 Vibrating grate switch
- 5 Rotor/stator forward/reverse
- 6 Safety default light
- 7 Current supply light
- 8 LED code display

STEP-UP 120

PROGRESSIVE CAVITY PUMP: SCREW PUMP FOR PUMPING AND SPRAYING APPLICATIONS

THE STEP-UP 120 SPRAY AND GROUT PUMP

Pump or spray mortars, stuccos, grouts, restoration mortars, underlayments, fireproofing, waterproofing, and many other materials. The 3 phase power gives you more horsepower to push material further and with more flow and grouts up to 3/8" aggregate.

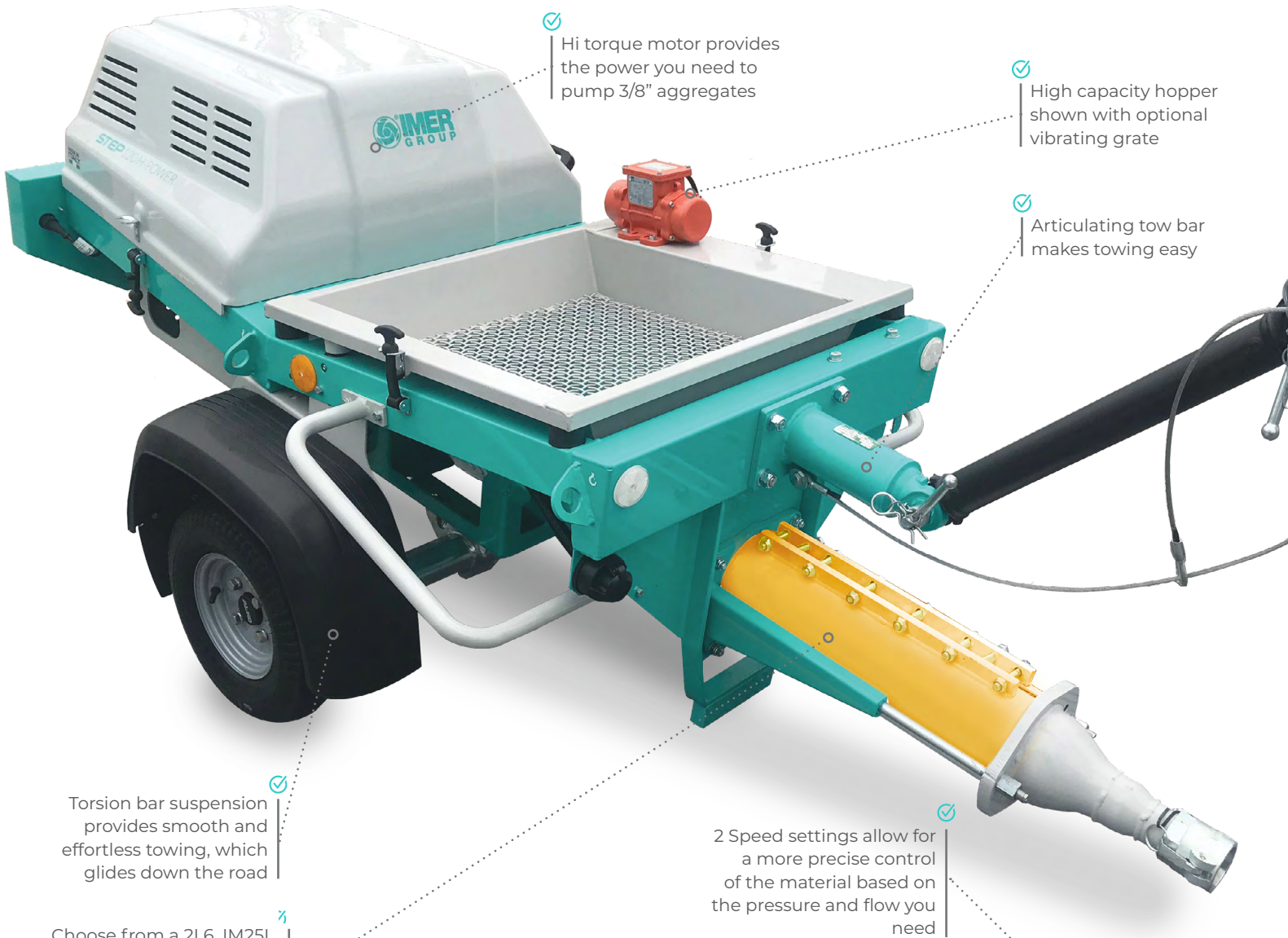

Hi torque motor provides the power you need to pump 3/8" aggregates

High capacity hopper shown with optional vibrating grate

Articulating tow bar makes towing easy

Torsion bar suspension provides smooth and effortless towing, which glides down the road

Choose from a 2L6, IM25L, 60.12 or L7 rotor / stator to maximize the most potential from the 7.5 HP motor

2 Speed settings allow for a more precise control of the material based on the pressure and flow you need

Technical specifications



















STEP-UP 120	
Model #	1106181
Motor power rate	7.5 hp
Mixer power rate	2 hp
Electric compressor	3 hp / 11 cfm
Max aggregate size	3/8"
Hopper capacity	4.25 cu ft
Dimensions w/l/h	33 in x 80 in x 38 in
Weight	616 lbs.

(*) The pumping distance will vary depending upon the type of material being used.



STEP-UP 120 APPLICATIONS

✓ Required ✓ Optional

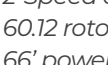
Product / Part #	Pumping of grouts, self-leveling underlayments	Spraying fireproofing	Low volume shotcrete	Decorative overlays	Grouts with 3/8" aggregate
 120' Remote control Part # 1107574	✓	✓	✓	✓	✓
 Remote control extension cable Part # 1107544	✓	✓	✓	✓	✓
 Piston compressor, 3 phase Part # 1107585		✓	✓		
 53' x 13 mm Air hose w/ Geka - Part # 1107532 33' x 13 mm Air hose w/ Geka - Part # 1107531		✓	✓		
 2L6 Rotor/stator kit Part # 1107088	✓	✓	✓		
 60.12 Rotor/stator kit Part # 1107090	✓	✓	✓	✓	
 Vibrating grate Part # 1107592	✓		✓	✓	
 L7-1.5 Rotor/stator kit Part # 1107660	✓		✓	✓	✓
 33' x 35 mm Material hose Part # 1107528	✓	✓	✓		
 33' Material hose Ø 50 mm (2") w/cam couplings - Part # 1107533	✓	✓	✓	✓	✓
 50mm to 35 mm Material hose reducer Part # 1106178	✓	✓	✓		
 Non-towing wheel kit Part # 1107633	✓	✓	✓	✓	✓
 Spray gun step 120 Part # 1107577		✓	✓		
 Shotcrete gun Part # 1106250			✓		
 5' Overhead wand Part # 1107549		✓	✓		
 16' x 35 mm male to 25 mm male hose Part # 1107074		✓	✓		
 Pintle tow ring Part # 1107161	✓	✓	✓	✓	✓

STANDARD EQUIPMENT 3 PHASE

- . 2-Speed control panel
- . 60.12 rotor/stator
- . 66' power cord
- . 7.5 HP, 2 speed, 3 phase 100% duty-cycle motor
- . Grate for premixed materials
- . Tow kit
- . Remote control ready
- . Accessory toolbox

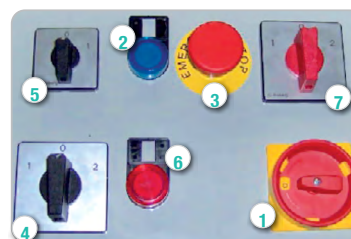

- 1 On/Off switch
- 2 Current supply light
- 3 Emergency stop button
- 4 Rotor/stator forward/reverse
- 5 Vibrating grate switch
- 6 Fault indicator light
- 7 Speed control switch

PRESTIGE 300

PROGRESSIVE CAVITY PUMP: SCREW PUMP FOR PUMPING AND SPRAYING APPLICATIONS

A MASTERPIECE OF PUMP ENGINEERING IN ONE COMPLETE PACKAGE

The Prestige 300 is a diesel-powered multi-purpose pump and spray machine with a built-in 6.3 cubic foot hydraulic mixer and onboard compressor for spraying. The military spec control panel integrates all these functions in one location, allowing operators to quickly and easily learn to operate the pump. Known for its versatility, the Prestige is designed to use different rotor/stator combinations for pumping a wide range of materials - including up to 3/8" aggregate with the optional L7 rotor / stator.

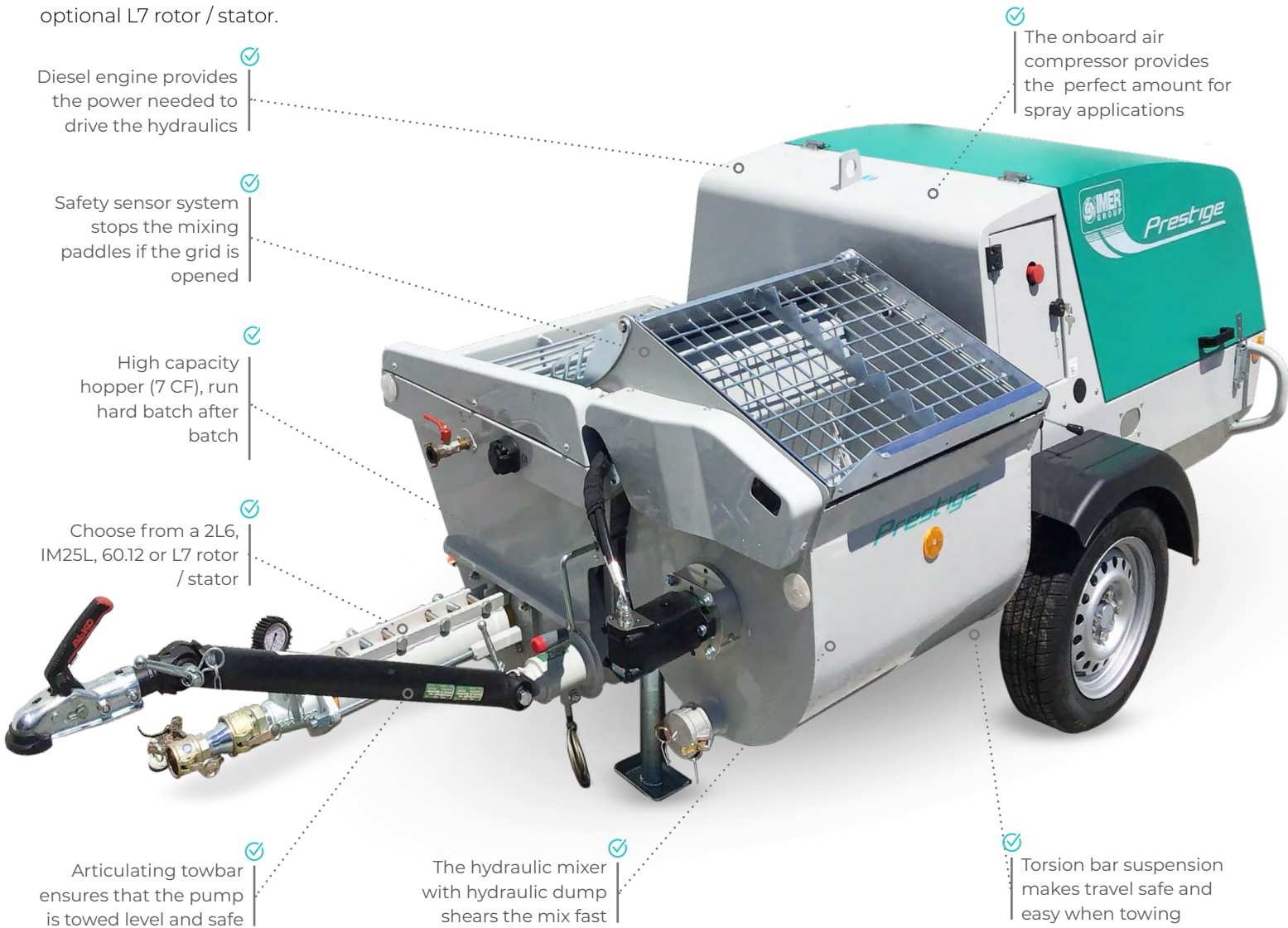

✓ Diesel engine provides the power needed to drive the hydraulics

✓ The onboard air compressor provides the perfect amount for spray applications

✓ Safety sensor system stops the mixing paddles if the grid is opened

✓ High capacity hopper (7 CF), run hard batch after batch

✓ Choose from a 2L6, IM25L, 60.12 or L7 rotor / stator

✓ Articulating towbar ensures that the pump is towed level and safe

✓ The hydraulic mixer with hydraulic dump shears the mix fast

✓ Torsion bar suspension makes travel safe and easy when towing

ANTI-VIBRATION CONTROL

Best in class control panel complete with pressure gauges and indicators.

OPTIONAL

Add the optional electronic water flow meter, to precisely measure your water to the mixer.



AGGRESSIVE & EFFICIENT

IMER's mixer paddles aggressively mix the material, this ensures clump free mud in the shortest time possible.



















Technical specifications

PRESTIGE 300	
Model #	1106433
Engine* - Diesel	24 hp
Compressor flow rate	14 cf/m
Max pumpable aggregate size IM25L	3/8 in
Hopper capacity	7 cu ft
Mixer capacity	6.3 cu ft
Dimensions w/l/h	131.5 in x 55.5 in x 53 in
Weight	1,653 lbs.

(*) Warning: Cancer and Reproductive Harm - <https://www.p65warnings.ca.gov>
 (**) The max flow rate and the max pumping pressure cannot be performed at the same time.

PRESTIGE 300 APPLICATIONS

Required Optional

Product / Part #	Pumping of grouts, self-leveling underlayers	Spraying fireproofing	Mortar and stucco setup	Shotcrete	3/8" aggregate
 33' of Ø 35 mm hose Part # 1107528	✓	✓	✓		
 33' of Ø 50 mm hose Part # 1107533	✓	✓	✓	✓	✓
 Aqua Control Electronic Meter System Part # 1107209	✓	✓	✓	✓	✓
 Vibrating grate Part # 1107036	✓		✓	✓	✓
 Four-function remote control w/164' cable Part # 1107086	✓	✓	✓	✓	✓
 IM25L Rotor/stator kit Part # 1107149	✓	✓	✓		
 60.12 Rotor/stator kit Part # 1107090	✓	✓	✓	✓	
 L7 - 1.5 Rotor/Stator Kit (4" Heavy-Duty Connection, w/2" HD Reducer) Part # 1107661				✓	✓
 50 mm to 35 mm material hose reducer Part # 1106178	✓	✓	✓		
 Spray gun 35 mm Part # 1107577		✓	✓		
 16' x 35 mm male to 25mm male hose Part # 1107074		✓	✓		
 Pintle tow ring Part # 1107161	✓	✓	✓	✓	✓
 Shotcrete gun Part # 1106250				✓	
 5 Function radio remote Part # 1107001	✓	✓	✓	✓	✓
 Hydraulic power washer Part # 1107208	✓	✓	✓	✓	✓
 5' Overhead wand Part #1107549		✓	✓		
 53' x 13 mm Air hose w/ Geka - Part # 1107532 33' x 13 mm Air hose w/ Geka - Part # 1107531		✓	✓		

STANDARD EQUIPMENT PRESTIGE 300

- 24 HP diesel engine
- 14 CF/m compressor
- 2L6 adjustable rotor/stator
- High-shear hydraulic mixer
- Programmable mixer timer
- Metal accessory box
- 2 clean-out sponges
- Tow package highway use
- Variable speed electro-hydraulic controls



STANDARD ROTOR / STATOR
2L6 Rotor Part # 1107078
2L6 Stator Part # 1107077



- 1 Increase/Decrease mixer speed
- 2 Vibrator on / off switch
- 3 Emergency stop button
- 4 Pump forward / Reverse switch
- 5 Mixer automatic cycle switch
- 6 Pump speed selector
- 7 Program water delivery
- 8 Pressure washer switch
- 9 Local / Remote selector
- 10 Diesel engine start

BOOSTER 20 BOOSTER 15

PISTON PUMP: 2-CYLINDER PISTON PUMP WITH "S" VALVE

COMPACT TOWABLE HIGH-PERFORMANCE DIESEL CONCRETE PISTON PUMP

Although it has high-performance output, the compact design of the Booster 20 allows it to function on job sites with limited space - where no other pumps of its capability could fit. This pump is designed and built to provide up to 20 cubic yards per hour of concrete, shotcrete, and high strength grouts.



Technical specifications







BOOSTER 20	
Model #	1106427
Engine* - Diesel	3-cylinder
Installed power rate	28 hp
Pumping system	2-cylinder w/ hydraulic control
Max aggregate size	1 in
Flow rate (**)	3 - 20 cu yd / hr
Pumping pressure (*)	1,000 psi
Pipe outlet	Heavy duty 4 in
Hopper capacity	7 cu ft
Loading height	42.5 in
Width	58 in
Length	161 in
Height	60 in
Weight	3,100 lbs.

(*) Warning: Cancer and Reproductive Harm - <https://www.p65warnings.ca.gov>
 (**) The max flow rate and the max pumping pressure cannot be performed at the same time.



BOOSTER 20 APPLICATIONS

✓ Required ✓ Optional

Product / Part #	Pumping of 3/4" concrete	Shotcrete	Grout or Self Consolidating Concrete (SCC) 3/8"
 Hydraulic power washer Part # 1107171 	✓	✓	✓
 5 Function radio remote Part # 1107001	✓	✓	✓
 Four-function remote control w/ 164' cable Part # 1107086	✓	✓	✓
 Rubber hopper extension kit (13 cu ft) Part # 1107196	✓	✓	✓
 Steel hopper extension kit (17 cu ft) Part # 1107197	✓	✓	✓

STANDARD EQUIPMENT BOOSTER 20

- . 3-cylinder liquid-cooled diesel engine
- . Automatic greasing system
- . Concrete hopper with agitator
- . Vibrating grid, 12V
- . Hydraulic system with reverse
- . Pumping unit with S-valve - automatic compensation of clearance and wear
- . 4" Heavy-duty delivery manifold
- . Full-featured electric control panel
- . Piston head installation and extraction tool kit
- . Complete w/ heavy-duty highway tow package
- . Accessory box with grease pump
- . Centralized grease ports
- . 4" Cleaning balls
- . Surge brakes
- . Wheel chocks
- . Parking brake

CONTROL PANEL



Stainless steel control panel complete with LED indicators and hydraulic gauges

ROTOR/STATOR PUMP KITS

Mortar, Stucco and Fireproofing Gun Kit Part # 1107005



- . Spray gun cpl. with deflector Ø12 for conventional mortar and deflector Ø10-14 for premixed mortar
- . Material hose Ø 25 mm, 50' (15 m) with cam couplings
- . Air hose Ø 13 mm, 53' (16 m) with Geka couplings
- . Accessory box with 1 spray gun cleaner and sponge ball Ø 30 mm

Grout Injection kit Part # 1107006



- . Injection gun + 1 deflector with hose connector Ø 16 mm
- . Pressure metering unit and pressure switch
- . Material hose Ø 25 mm, 33' (10 m) with cam couplings
- . Material hose Ø 25 mm, 15' (5 m) with cam couplings
- . Accessory box with 1 spray gun cleaner and sponge ball Ø 30 mm

Stucco and fine coatings gun kit Part # 1107010



- . Spray gun for finish coats, waterproofing, and fine coatings
- . Deflectors Ø5 - Ø6 - Ø8 - Ø12 mm
- . Deflector with hose connector Ø 16 mm
- . Material hose Ø 25 mm, 33' (10 m) +16' (5 m) with cam couplings
- . Air hose Ø 13 mm, 53" (16 m) with Geka couplings
- . Spray gun cleaner and sponge Ø 30 mm

Tuckpointing gun kit Part # 1107504



- . Auto On/Off gun kit for tuck pointing
- . 24V Remote cable (On/Off)
- . Reducer for 19 mm hose coupler
- . 25 mm hose coupler
- ** Requires D5 2.5 Rotor & Stator & 33' x 19 mm material hose



GERRIS 800

CRAWLER CONCRETE PLACING BOOM

PLACE CONCRETE EASILY AND EFFICIENTLY

The Gerris 800 is a self-propelled crawler concrete placing boom, with a small footprint (2' 7" x 16' 2") and minimal weight. It is used to distribute pumped concrete, in any position within its range of about 26' - 3" and up to a height of 36' 9". The distribution boom requires minimal space for it to open (9' 2"), allowing it to operate even in places with low ceilings. The unit is radio-controlled, simple and intuitive to maneuver and position in the working area. This machine is suitable for placing pumped concrete with a maximum aggregate size of 1". Pair it directly with any concrete pump with 4" HD fittings. Bi-Energy: gas engine and electric auxiliary 120V motor allows it to work in closed work environments. Lithium option is also available.

4" heavy duty pipe runs along the boom sections

3 boom sections allow placing concrete in just about any position

Honda GX390 engine with electric start powers the hydraulics

4 self-leveling outriggers allow for quick setup on most any terrain

4" flex hose helps to place the concrete where you need it



Comes standard with wireless remote controller

Run on 120V power when the situation warrants

Expandable tracks allow for extra stability



TAKE IT ALMOST ANYWHERE

The Gerris 800 folds up to fit through standard doorways, and with its light ground pressure and overall weight, it makes the perfect companion to place concrete where you need it.



Technical specifications

GERRIS 800	
Model # (Lithium)	1128758 (1128786)
Max height	37 ft
Maximum reach	26 ft
Depth of casting	16.5 ft
Maximum aggregate size	1 in
Overall dimensions stabilized	9' 7" - 10' 1"
Maximum speed	0 - 1.6 mph
Gradeability	25%
Turret rotation	355°
Gasoline engine	Honda GX390 (13HP)
Lithium Electric Motor	48 V / 5.4 HP AC
Auxiliary electric motor (gas model only)	120V, 1.5HP
Transport width	2' 7"
Transport length	16' 1"
Transport height	6' 6"
Weight	5,512 lbs.

IMER EARTH MOVING

TRACKED BUGGIES AND DUMPERS



GAS & ELECTRIC POWERED TRACKED TRANSPORTERS

IMER Earth Moving's Track Driven Powered Mini-dumpers, buggies and skid steers are the ideal solutions to transport and handle various types of materials and provide excellent traction on grades, inclines, and soft soils. Gas and Diesel powered options are designed to tackle larger outdoor projects.

From mini-dumpers to lift and haul smaller materials to larger buggies with a 180-degree pivoting dump, as well as the SL3730 mini skid steer, the family of versatile machines can be equipped with a wide range of accessories, which may be easily changed by the quick and simple equipment coupling/uncoupling system.

Each machine is designed with the comfort and safety of the operator in mind. Added safety features and ergonomic designs help the operator be more productive and stay safe throughout the workday. When an operator stops, even in a state of idling, the machine stops.

The control consoles on each machine are simple and intuitive, and a control lever protection bar is a convenient armrest for the operator, while the control levers are connected directly to the control valve to ensure an accurate, progressive response.

Each day, IMER Earth Moving engineers are working to develop new models and attachments to make work easier, and safer.



TRACKER 811 (CARRY 105)

GAS POWERED TRACKED MINI-DUMPER

LOAD N' GO SMALL, VERSATILE MACHINE

The new Tracker 811 mini-dumper is a highly agile and versatile machine, small in size, yet able to handle a large load on all kinds of terrain, including steep gradients. The Tracker 811 standard models include a steel Tipping Bucket. The Tracker 811 mini-dumpers may be equipped with a wide range of accessories to meet various requirements, including the Self-loading Shovel, or the Dumping Platform Bed with Opening Sides.

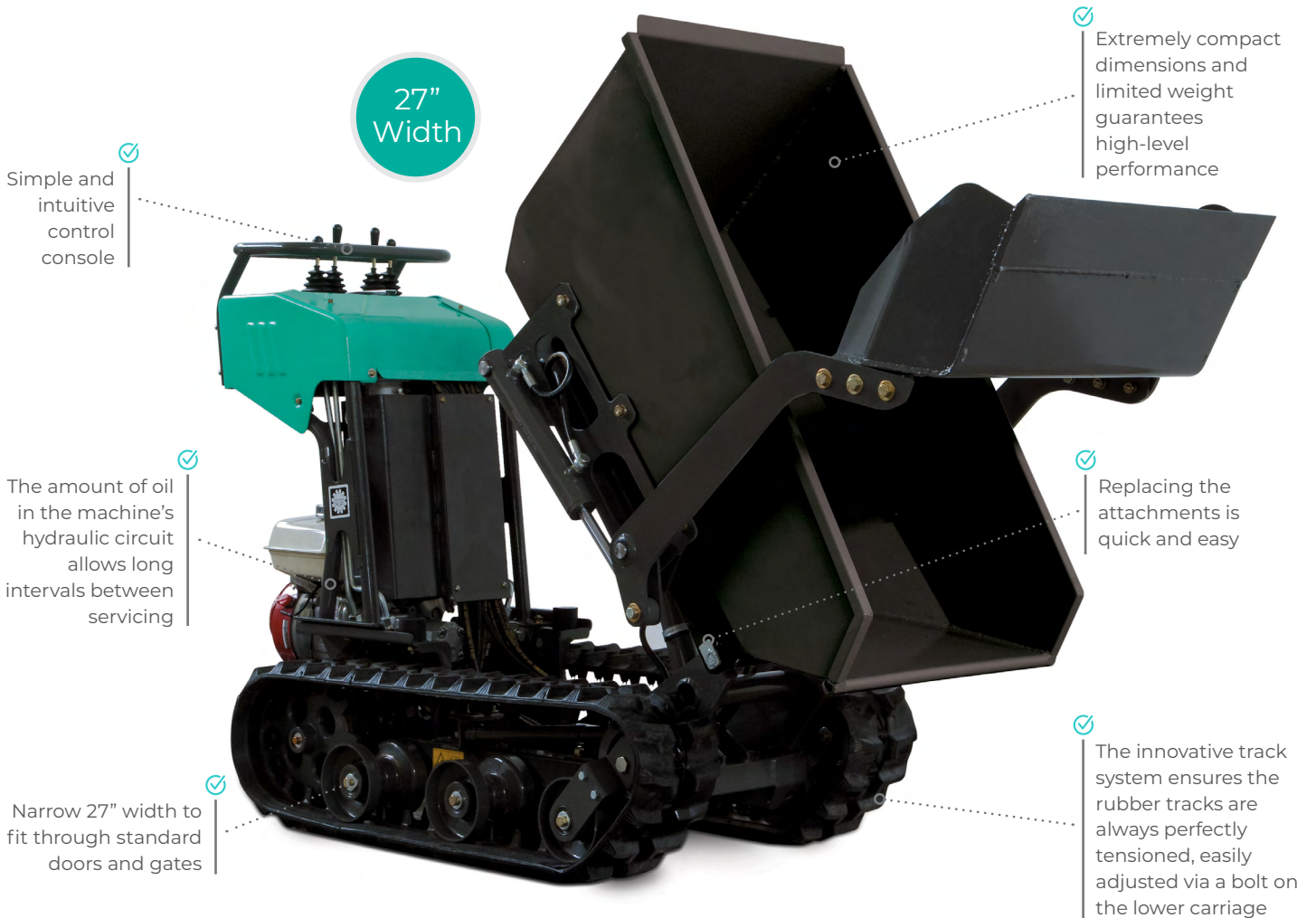

SAFETY AND STANDARDS
The Honda engine is low noise, which meets established noise pollution standards. The engine is mounted on vibration dampers to significantly reduce the amount of vibration transmitted.



OPTIONAL DUMP PLATFORM WITH OPENING SIDES
Model # 5180301002HD

The dump platform accessory is perfect for transporting and unloading bulky materials from 3 sides of the platform bed.



Technical specifications

POWERED by **HONDA**

TRACKER 811

Model #	5105001
Engine*	Honda GX200, 6.5 hp
Machine weight	640 lbs.
Operating load	1,102 lbs.
Payload capacity	8 cu ft
Speed	2 mph
Max allowed slope when empty	20° - 36%
Max allowed slope when loaded**	11° - 20%***
Ground clearance	4 in
Length	62.5 in
Height	44.5 in
Width	27 in

(*) Warning: Cancer and Reproductive Harm - <https://www.p65warnings.ca.gov>
(**) Guide with operator on the ground, where applicable (***) Variable based on the configuration

TRACKER 1215 (CARRY 107)

GAS OR ELECTRIC POWERED TRACKED MINI-DUMPER

A COMPACT, YET POWERFUL TRACKED DUMPER BOASTS A 13HP HONDA ENGINE

The Tracker 1215 mini-dumper is the ultimate 1-person ride-on hauler. Designed with a compact 30" width to fit through the narrowest of backyard gates or interior doors. While conventional buggies and tracked machines do not offer an extendible undercarriage, the rubber tracks on the Tracker 1215 can extend from 30" to nearly 42" in width to provide the added stability required on challenging job sites with hills and uneven slopes, plus the extended track provides added protection to lawns and floors, preventing unwanted damage. Available in both gas and lithium powered configurations.



SAFETY AND STANDARDS

The Honda engine is low noise, which meets established noise pollution standards. The engine is mounted on vibration dampers to significantly reduce the amount of vibration transmitted.



EASY TO USE CONTROLS

Uncluttered, convenient, and intuitive controls allow for easy 1 person operation. The surrounding grab bars provide the operator added safety when driving and a convenient armrest when idling.



POWERED by HONDA Technical specifications

	TRACKER 1215	TRACKER 1215E
Model #	5107001	5107003
Engine	Honda GX390, 13 hp	4 HP Electric
Machine weight	950 lbs.	1,315 lbs.
Operating load		1,543 lbs.
Payload capacity		11.6 cu ft
Speed	2.5 mph	2 mph
Max slope when empty		15° - 26%
Max slope when loaded		7° - 12%***
Ground clearance		4 in
Length		72 in
Height		44.5 in
Width		30 in
Start	Electric	N/A

(*) Warning: Cancer and Reproductive Harm - <https://www.p65warnings.ca.gov>
 (***) Guide with operator on the ground, where applicable (***) Variable based on the configuration

TRACKER 1215 ATTACHMENTS

TRACKER 1215 - DUMPER ATTACHMENTS

ACCESSORY KITS PROVIDE ADDED VERSATILITY AND ROI

The Tracker 1215 mini-dumper offers a full range of attachments that handle every aspect of material handling and multiple applications. Easily convert one machine into six different machines - including a Self-loading Shovel, Dump Platform, Concrete Mixer with Self-loading Shovel, Levelling Blade, and the Hi-Tip Bucket and Self-loading Shovel kit.



SELF-LOADING SHOVEL



1

DUMP PLATFORM



5

LEVELLING BLADE



2

4

HI-TIP BUCKET WITH SELF-LOADING SHOVEL



3

CONCRETE MIXER WITH SELF-LOADING SHOVEL



63" Unloading Height



ELECTRIC



SWAPPABLE LITHIUM BATTERIES

3 fast charging, high capacity lithium batteries.



6 SPEEDS (3X2)

Three electric speeds and two hydraulic speeds for maximum versatility



DIGITAL DISPLAY

Shows battery levels and other diagnostic information from the machine.



TRACKER 1624 (CARRY 110)

GAS POWERED TRACKED MINI-DUMPER

HIGH-PERFORMING, POWERFUL, AND FUNCTIONAL DUMPER

The Tracker 1624 checks all the columns for the busy concrete contractor. From driveways to patios and across rough terrain, this tracked unit can handle it. Equipped with a poly tub and IMER's expected dedication to quality of design and manufacturing, this latest addition to IMER's large line of track dumpers will satisfy your needs. Powered by Honda's latest and most powerful electronic controlled gasoline engine, it also features 3-level speed control, auto idle, and electronic controlled start up. Can Bus digital touch screen dashboard provides information on hours, battery voltage, fuel consumption, percentage engine load, and diagnostic capabilities. For operator comfort the platform is double rubber shock mounted and features a hydraulic joystick for speed control.



CAPACITY
16 CF

SWIVEL MODEL AVAILABLE
Model # 5110002



✓ Low discharge height to prevent splashing

Technical specifications **POWERED by HONDA**

TRACKER 1624	
Model # (Fixed Bucket)	5110001
Model # (Swivel Bucket)	5110002
Machine weight	1,521 lbs.
Operating load	2,400 lbs.
Payload capacity (struck/heaped)	16 cu ft / 19 cu ft
Speed (forward/reverse)	6 mph / 2.5 mph
Max allowed slope (empty)	20° - 36%
Max allowed slope (loaded**)	11° - 20%***
Ground clearance	5.5 in
Length	75.5 in
Height	52 in
Width	35 3/8 in
Start	Electric

(*) Warning: Cancer and Reproductive Harm - <https://www.p65warnings.ca.gov>
(**) Guide with operator on the ground, where applicable (***) Variable based on the configuration

IMER CLEAN AND SHIELD

CONCRETE CLEAN UP MADE EASY

IMER Clean and Shield are a superb all-natural non-toxic Mortar and Concrete Dissolver designed to melt away any type of cementitious material, whether concrete, stucco, mortar, or grout.

Used on cured cement based materials to eat away the portland cement. Save labor cleaning tools and equipment, and save your equipment from the damage hammers and chisels cause.

Soak the buildup, let IMER Clean work awhile and then wash it away.

Neutralize with only water.



IMER CLEAN Model # 4100030 Case (12 - 22oz Bottles)
4100070 5 Gallon Container, # 4100050 Gallon

IMER SHIELD Model # 4100011 Case (12 - 22oz Bottles)



- ✓ 100% biodegradable "green" product
- ✓ Contains No muriatic, sulfuric, or phosphoric acids
- ✓ Will not harm painted surfaces, metal, plastic, plants or vegetation
- ✓ Wash away with water



IMER CLEAN REMOVES:

- Cured concrete
- Mortar
- Stucco
- Grout
- Thin set

IMER CLEAN WORKS ON:

- Trowels
- Mixers
- Shovels
- Wheelbarrows
- Mud Tubs
- Pumps
- Molds
- Forms
- Concrete Saws
- Cement trucks
- Augers
- Conveyors
- Scaffold
- Silos
- Aerial Lifts
- Wall and Deck Splashes



1 Gallon IMER Clean Spray

TRACKER 2833 (CARRY 150)

DIESEL POWERED ALL-TERRAIN 180° SWIVEL TRACKED CRAWLER

POWER, SPEED AND 180° SWIVEL DUMP

The Tracker 2833 has an independent dual circuit hydrostatic transmission with a variable displacement axial piston pump and a dual displacement axial piston hydraulic motor for each track. The standard Tracker 2833 model offers a 180° hydraulic lift and swivel bucket to handle a multitude of loading/unloading options.

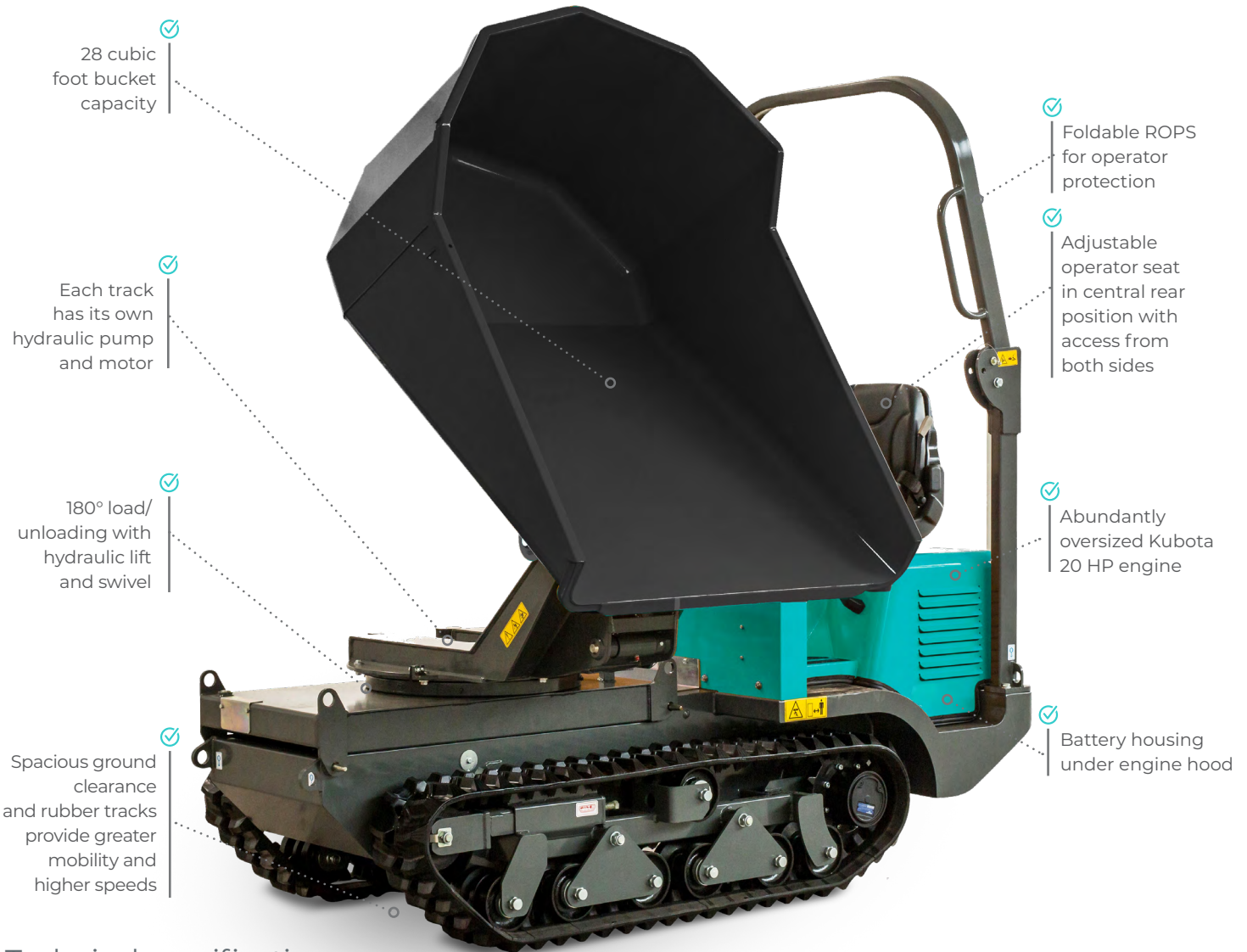

Technical specifications

TRACKER 2833	
Model #	5150002
Engine* - Diesel	D902, 20 hp
Machine weight	1,896 lbs.
Operating load	3,307 lbs.
Payload capacity	28 cu ft
Speed	5 mph
Max allowed slope when empty	32° - 62%
Max allowed slope when loaded**	32° - 62%***
Ground clearance	9.5 in
Length	107 in
Height	93.75 in
Width	42.5 in
Start	Electric

INTUITIVE CONTROLS

The control panel is easy to access and operate. Drive and operate the Tracker 2833 from the protected operator's seat located behind the swiveling bucket.



(*) Warning: Cancer and Reproductive Harm - <https://www.p65warnings.ca.gov>
 (***) Guide with operator on the ground, where applicable (***) Variable based on the configuration

TRACKER 4150 (CARRY 230)

DIESEL POWERED ALL-TERRAIN 180° SWIVEL TRACKED CRAWLER

THE LARGEST BUCKET IN THE FLEET BOASTING 180° CAPABILITY

The Tracker 4150 tracked dumper is the most powerful machine in the IMER fleet. With a 24.8 HP Kubota Diesel engine, hydraulic transmission, 10-½" wide tracks, and a 41 cubic foot steel bucket, the Tracker 4150 is built to move and unload a multitude of material like concrete and stone quickly and efficiently.



EASY TO USE CONTROLS
Uncluttered, convenient and intuitive controls allow for easy 1 person operation. Ergonomic seating and control design provides added operator comfort.



SELF-LOADING SHOVEL AND BUCKET KIT OPTION

Model # 5240335101HD

The Tracker 4150 Trilateral Tipping Bucket & Self-loading Shovel kit scoops and dumps from multiple positions.



Technical specifications

	TRACKER 2833
Model #	5230001
Engine* - Diesel	V1505, 24.8 hp
Machine weight	5,038 lbs.
Operating load	5,070 lbs.
Payload capacity	41.3 cu ft
Speed	5 mph
Max allowed slope when empty	25° - 46%
Max allowed slope when loaded**	21° - 38%***
Ground clearance	9.75 in
Length	127.25 in
Height	99.75 in
Width	51 in
Start	Electric

(*) Warning: Cancer and Reproductive Harm - <https://www.p65warnings.ca.gov>

(**) Guide with operator on the ground, where applicable (***) Varies

SL3730

DIESEL POWERED SKID STEER

COMPACT, RELIABLE, WITH PILOT OPERATED JOYSTICK CONTROLS

The SL3730 is ideal for working in confined spaces with maximum flexibility. With an operating weight of 2955 lbs., the SL3730 can handle an operating load (SAE Standard) of up to 728 lbs., with a breakout force of 1658 ft/lb. The SL3730 Skid Steer Loader is equipped with a 21 Hp. Yanmar Diesel engine ensuring excellent performance in the most complex applications.



✓ Enclosed cabin is optional

✓ Auxiliary hydraulics makes it easy to hookup options

✓ 37 inches wide to fit through most gates and tight spaces



✓ Auto-leveling bucket comes standard



Technical specifications

	SL-3730
Model #	SL-3730
Engine* - Diesel	Yanmar, 21 hp
SAE Load Capacity 35%	728 lbs.
Tipping Load 50%	1,455 lbs.
Bucket Breakout Force	1,658 ft/lb
Max. Speed	4.5 mph
Fuel Tank Capacity	2.2 gal
Hydraulic Pressure	2,610 psi
Auxillary Flow	7.4 gpm
ROPS Compliance	ISO 3471:1994
FOPS Compliance	ISO 3449:1998 Ivl 1

EASY TO USE PILOT CONTROLS



AUXILLARY QUICK CONNECTS

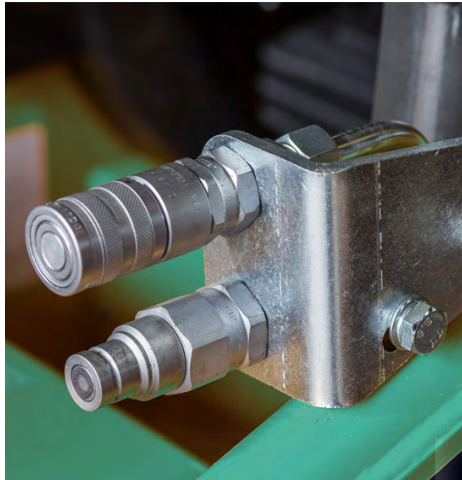

MAINTENANCE MADE EASY

The machine is designed to be easy to service with minimal downtime: the rear hatch opens to 90° for comfortable access to both sides of the engine and oil tank. Two powerful jacks eliminate all effort in quickly tilting the cab out of the way for simplified access to the hydraulic pumps, motors, valves and fluid lines.

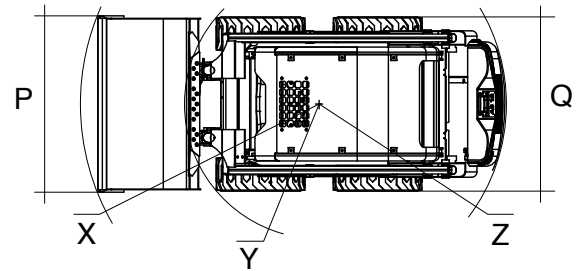
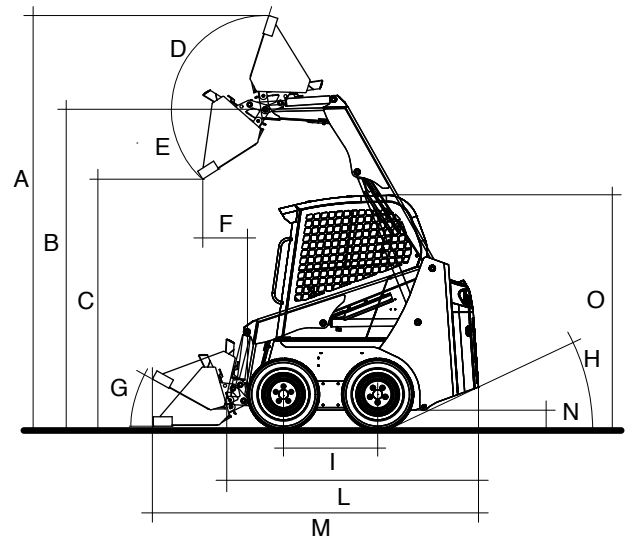

Working Ranges and Dimensions

SL-3730

A Operating Height - Fully Raised	10'10"
B Height to Hinge Pin - Fully Raised	8'4"
C Dump Height	6'8"
D Bucket Tilt Angle	112°
E Dumping Angle at Max Height	31°
F Dump Reach - Fully Raised	1'2"
G Maximum Rollback at Ground	34°
H Departure Angle	27°
I Wheel Base Length	2'6"
L Total Length (w/o bucket)	6'7"
M Total Length	8'6"
N Minimal Ground Clearance	6"
O Overall Height	6'2"
P Bucket Width	3'2" - 3'8"
Q Crawler Width	3'1" - 3'8"
X Front Clearance Radius (with bucket)	5'1"
Y Front Clearance Radius	2'8"
Z Rear Clearance Radius	3'11"

IM SERIES SCISSOR LIFTS

ELECTRIC POWERED SLAB SCISSOR LIFTS



IMER's Electric Scissor Lifts lead the industry with innovative technologies as a direct result of years of experience, concentrated research, and a goal to provide superior products that deliver unparalleled productivity and safety.

The IMER IM Slab Series includes eight models of scissors which all fill a unique void in the market and share innovative technologies while offering a commonality of parts, which simplifies maintenance and improves parts costs and accessibility.

Engineered to be compact and feature rich for easy clearance and maximum versatility. The reduced size, generous capacity, and optimized weight distribution ensure maneuverability in limited spaces with tight steering angles. Operators may

drive in any position, including at full height, providing superior productivity.

The IM Series scissors ensure the maximum capacity in both the platform and on the manual deck extension. They offer traction and stability at maximum height, even with multiple workers on the fully extended platform.

In addition to the standard features and accessories, IMER Group has developed **IMERVIEW**, a GPS system which makes it possible to monitor and/or control aerial machines remotely in real time.

PRODUCT RANGE

Micro Scissors

[IM 3113](#)

[IM 3116](#)

Full Size Scissors

[IM 3219](#)

[IM 3224](#)

[IM 3534](#)

[IM 3540](#)

[IM 4740](#)

[IM 4746](#)

STANDARD EQUIPMENT

- ANSI 92.20 / CSA / CE & EN280 approved
- Electric front wheel drive motors*
- Negative electromagnetic parking brakes with electric disengagement
- 90° steering
- Manual deck extension (holds two + people)*
- Manual emergency lowering device
- Cylinder holding valve
- Heavy duty traction batteries*
- Battery charger with automatic switch-off
- Audible motion alarm, horn, hour meter
- Tilt meter with motion cut out and alarms
- Mechanical wheel drive release for emergency hauling*
- Cushioned non-marking tires
- Electrical scissor protection
- Pothole protection
- Battery control system with low-voltage cut-out protection
- Fast action foldable railings*
- Platform weight management
- AC power to platform*
- Flashing beacon
- Proportional controls with diagnostics

*Only applies to full size scissors



UNMATCHED PLATFORM SIZE & EXTENSION

The remarkable size and length of the platform and the extension provides increased performance. Support multiple workers and tools on the extended platform - extending further than competitive lifts.

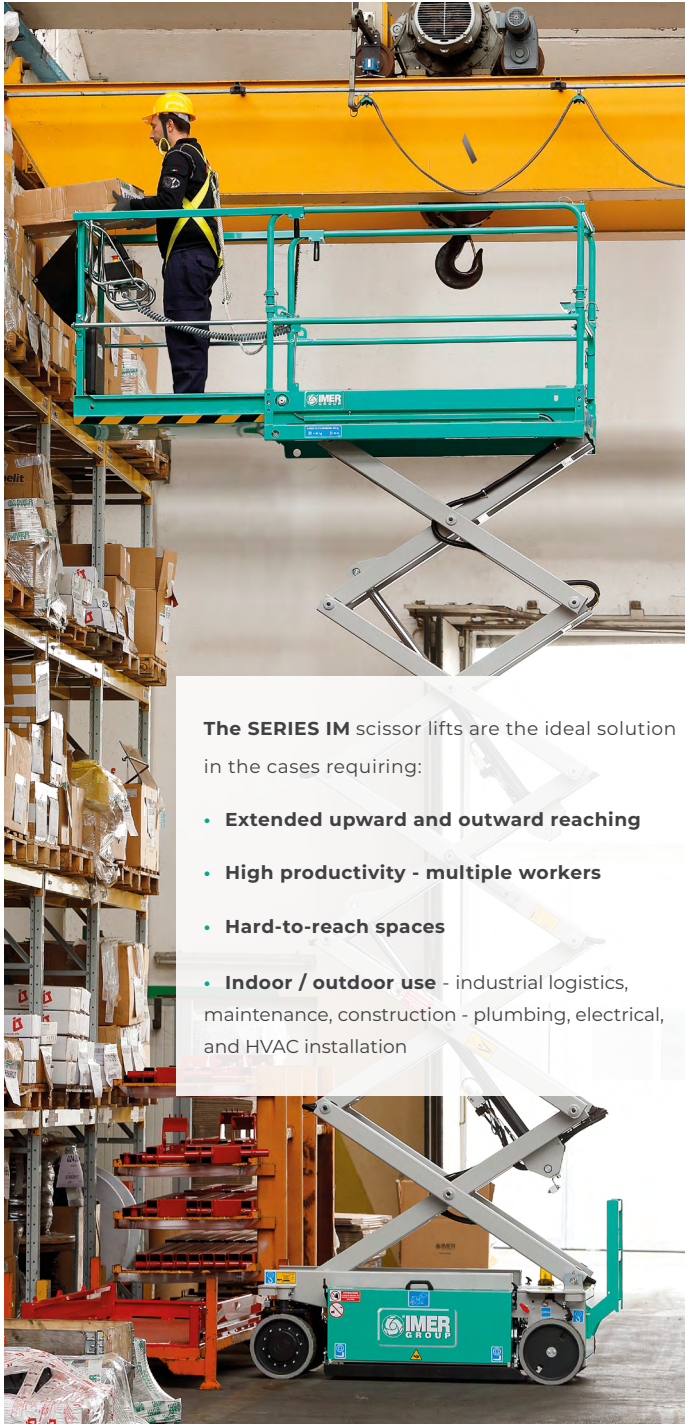

The **SERIES IM** scissor lifts are the ideal solution in the cases requiring:

- **Extended upward and outward reaching**
- **High productivity - multiple workers**
- **Hard-to-reach spaces**
- **Indoor / outdoor use** - industrial logistics, maintenance, construction - plumbing, electrical, and HVAC installation



PERFORMANCE VERSATILITY

Work and drive safely from any position, including full height. Offering 3 speeds to maximize performance.



IM SERIES SCISSOR LIFTS

ANSI A92.20, CSA & CE - EN280 COMPLIANCE

Every IM Series Scissor Model conforms to the European Standard safety requirements directed by the EN280, Canadian Standards Association (CSA), and the American National Standards Institute (ANSI) standards - receiving the EN280 marking and ANSI 92.20 approval. Also conforms to EE Rating, North America UL583.

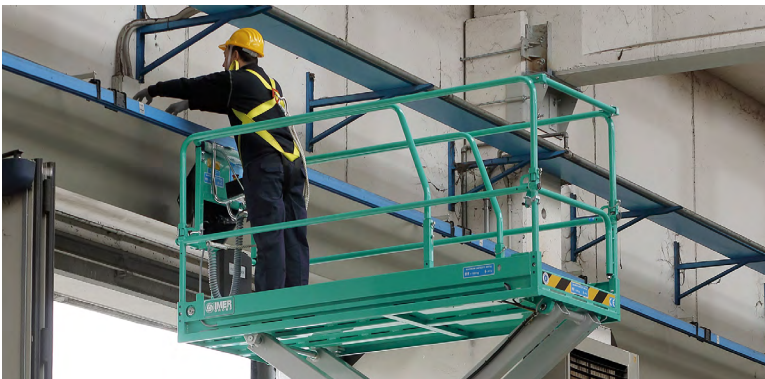

UNMATCHED SAFETY FEATURES

Every IM Series Scissor Model is built for operator safety and includes multiple safety features such as; a tilt meter with motion cut out and alarms, an overload sensor, a flashing beacon, and a manual emergency lowering device.

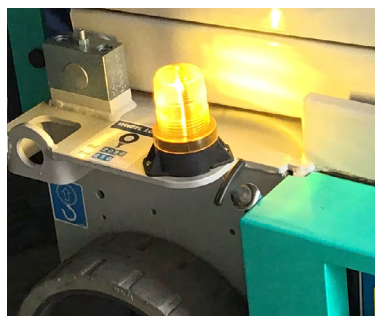

ONE-HAND INTUITIVE CONTROL

Sturdy, simple and intuitive control box on the platform allows for a smooth operation from any rail position or on the ground - removable for ground control operations. The interchangeable control box can be used on any full size IM Series Slab Scissor lifts.



C5 BATTERY MORE POWER

Securely protected high capacity batteries and the electric front-wheel-drive motor boosts your productivity with longer runtimes. Built around C5 technology means more amperage and torque to drive motors which enables driving, stopping and starting on a steep grade.



POTHOLE PROTECTION

Every IM Series Scissor Model provides a pothole protective undercarriage to stabilize the scissor and protect the operator. The cushioned non-marking tires continue to roll without interruption over potholes.

SUPERIOR MOBILITY

Narrow platforms and foldable guardrails allow for easy access through standard doorways and narrow aisles. The shorter wheelbase allows for a tighter turning radius for exceptional maneuverability.



HEAVY-DUTY FOLDING GUARDRAILS

All IM Series Scissors offer heavy-duty tubular foldable guardrails. The circular design provides more stability and strength than a square rail design.

NARROW FRAME & PLATFORM

Not only are all IM Series Scissors compact and narrow for maximum mobility, the undercarriages offer a protective metal cover to stop debris from lodging and slowing operation.



EXCEPTIONAL ACCESSIBILITY

Designed with full 90° steering capability, to move easily in tight spaces, plus easy serviceability without removing motor.



IM 31 SERIES

MICRO SCISSOR LIFTS

OUTDOOR AND INDOOR USE

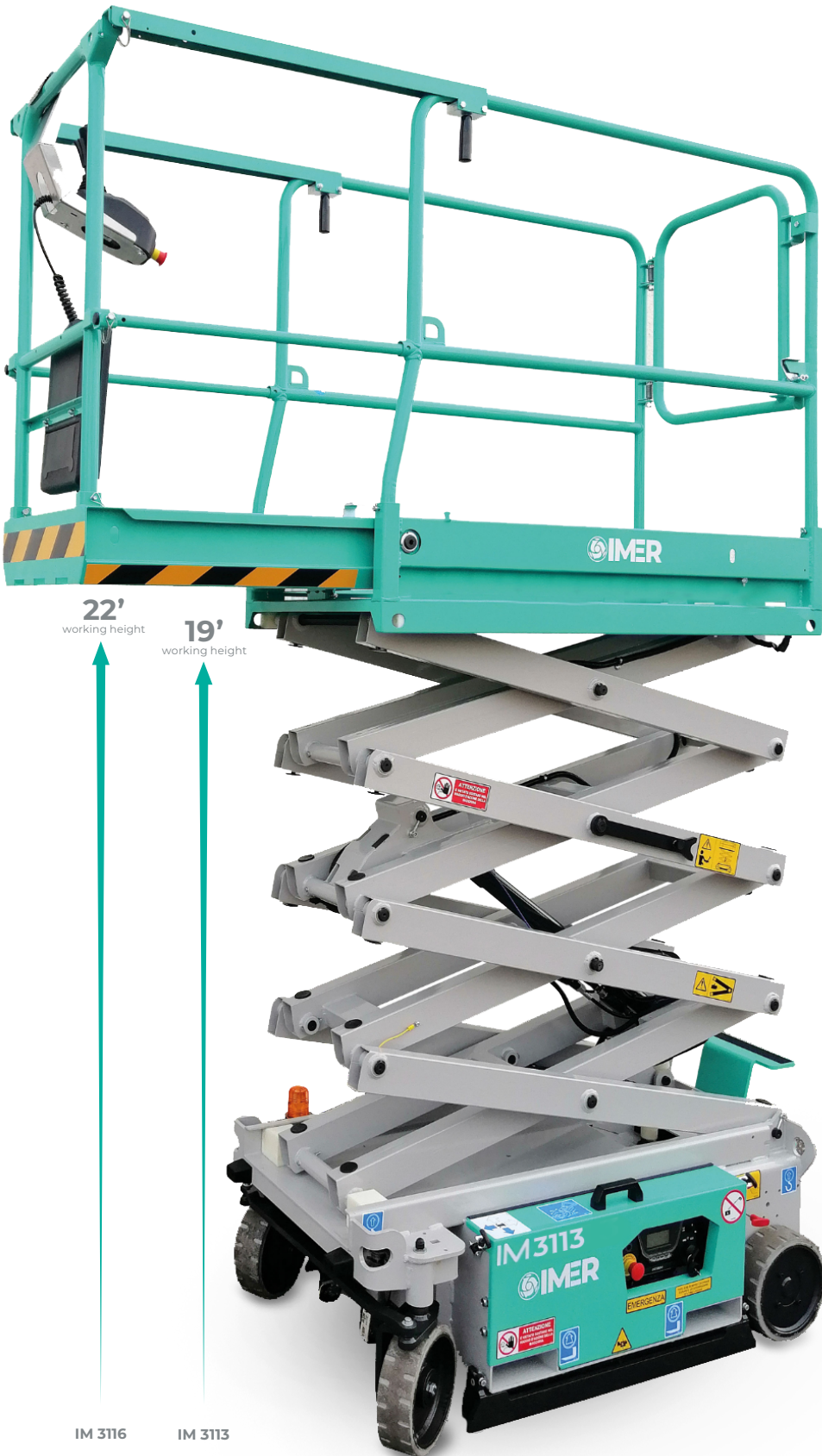

IM 3116

IM 3113



Micro Scissors come equipped with slimmed down controller



Front electric steering enabling maximum precision of movements.



AGM batteries to ease maintenance. New disposition of hydraulic components on the lower frame which integrates forklift pockets.



New ground control panel with integrated display for data retrieval and troubleshooting.

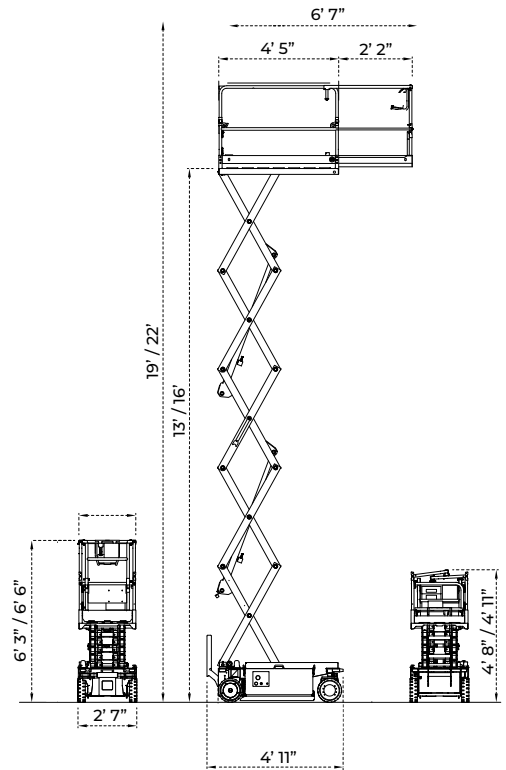

IM 31 SERIES

IM 3113

IM 3116

Model #	1128908		1128918	
Number of scissors	3		4	
Platform height	13' indoor 7' 4" outdoor	3,800 mm indoor 2,250 mm outdoor	16' indoor 8' outdoor	4,900 mm indoor 2,450 mm outdoor
Working height	19' indoor 13' 11" outdoor	5,800 mm indoor 4,250 mm outdoor	22' indoor 14' outdoor	6,700 mm indoor 4,250 mm outdoor
Stowed height	6' 3"	1900 mm	6' 6"	1990 mm
Folded height	4' 8"	1410 mm	4' 11"	1500 mm
Length (without ladder)	4' 11" (4' 5")	1490 mm (1335 mm)	4' 11" (4' 5")	1490 mm (1335 mm)
Width	2' 6"	780 mm	2' 6"	780 mm
Platform extension	2' 2"	660 mm	2' 2"	660 mm
Platform capacity	507 lbs.	230 kgs	507 lbs.	230 kgs
Capacity on platform extension	287 lbs.	130 g	287 lbs.	130 g
Authorized persons	1			
Traction motors	24 DC			
Batteries	2x12/85 C5 V/Ah			
Battery charger	24 V / 20 Ah			
Oil tank capacity	.5 gal	2 l	.5 gal	2 l
Max. lateral/longitudinal inclination	1.50 / 3.00°	1.50 / 3.00°	1.50 / 2.50°	1.50 / 2.50°
Max driving speed	2.5 mph	4 km/h	2.5 mph	4 km/h
Safety speed	0.4 mph	0.6 km/h	0.4 mph	0.6 km/h
Gradeability	25%			
Internal turning radius	9.5"	0.24 m	9.5"	0.24 m
External turning radius	61"	1.55 m	61"	1.55 m
Tires dimensions	9.8" x 3.1"	250 mm x 80 mm	9.8" x 3.1"	250 mm x 80 mm
Tires type	Cushion			
Weight	1,543 lbs.	700 kgs	1,653 lbs.	750 kgs

IM 32 SERIES

ELECTRIC SCISSOR LIFTS

OUTDOOR AND INDOOR USE

30'
working height



IM 3224



25'
working height



IM 3219

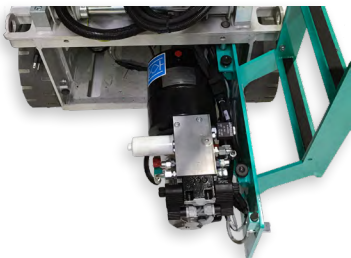

Easy to access standard hydraulic power pack with dual intake and output filters



Driveable at full height and fully extended



Manual deck extension of 39"



Foldable guardrails allow for easy access through standard doorways



39"
deck extension

extension supports
2 workers

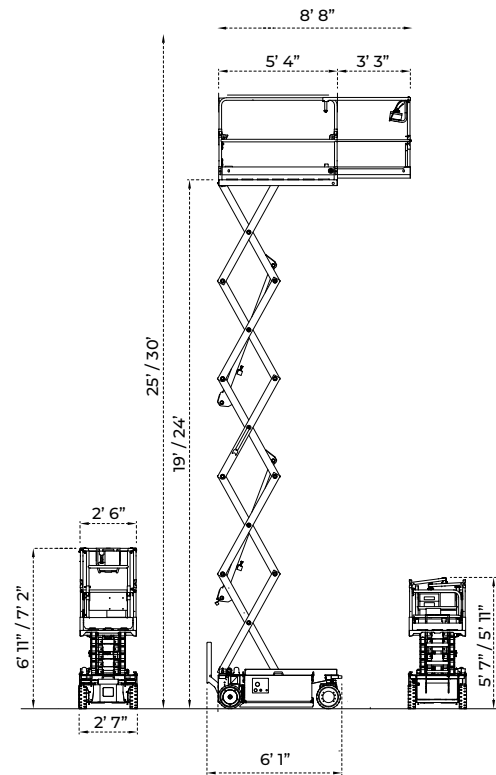

IM 32 SERIES

IM 3219

IM 3224

Model #	1128936		1128923	
Number of scissors	3		4	
Platform height	19' indoor 14' 5" outdoor	5800 mm indoor 4400 mm outdoor	24' indoor 17' 9" outdoor	7200 mm indoor 5400 mm outdoor
Working height	25' indoor 21' outdoor	7600 mm indoor 6400 mm outdoor	30' indoor 24' 3" outdoor	9200 mm indoor 7300 mm outdoor
Ground clearance (pothole up/down)	3.5" / .85"	90 mm / 22 mm	3.5" / .85"	90 mm / 22 mm
Stowed height	6' 11"	2100 mm	7' 3"	2200 mm
Height with guard railed folded	5' 7"	1700 mm	5' 11"	1800 mm
Capacity	507 lbs.	230 kg	507 lbs.	230 kg
Capacity on deck extension (outdoor)	507 lbs. (287 lbs.)	230 kg (130) kg	507 lbs. (287 lbs.)	230 kg (130) kg
Allowed operators (outdoor)	2 (1)			
Traction motors	24V / 3.2HP	24V / 2.4kW	24V / 3.2HP	24V / 2.4kW
Powerpack	24V / 3HP	24V / 2.2kW	24V / 3HP	24V / 2.2kW
Batteries	24V / 182 Ah			
Battery weight	64 lbs.	29 kg	64 lbs.	29 kg
Battery charger	24V / 20Ah			
Oil tank capacity	1.85 gal	7 l	1.85 gal	7 l
Max driving speed	2.5 mph	4 km/h	2.5 mph	4 km/h
Safety speed	.25 mph	.4 km/h	2.5 mph	.4 km/h
Gradeability	25%			
Internal turning radius	0'	0 m	0'	0 m
External turning radius	5' 5"	0.24m	5' 5"	0.24m
Tires dimensions	12.8" x 3.9"	325 x 100 mm	12.8" x 3.9"	325 x 100 mm
Tires type	Cushion			
Max side / longitudinal tilt angle	1.5 / 2.5°	1.5 / 2.5°	1.5 / 2.5°	1.5 / 2.5°
Weight	2,350 lbs.	1,070 kg	2,850 lbs.	1,300 kg

IM 35 SERIES

ELECTRIC SCISSOR LIFTS

40'
working height



IM 3534

46'
working height



IM 3540

OPTIONAL EQUIPMENT

- 120 V cable with plug, socket and safety cut-out (standard for US Models)
- Gel battery IM 35 series
- Additional flashing beacon kit
- Compressed air line

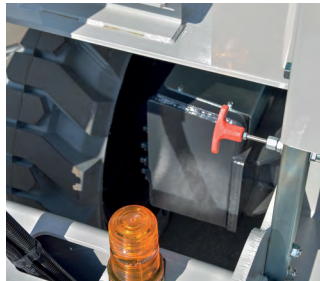

Standard manual emergency lowering device

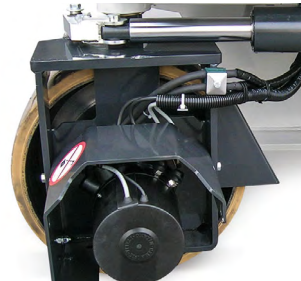

Standard negative electromagnetic parking brakes with electric disengagement



New design of the chassis allows easy cleaning and ensures protection to the components

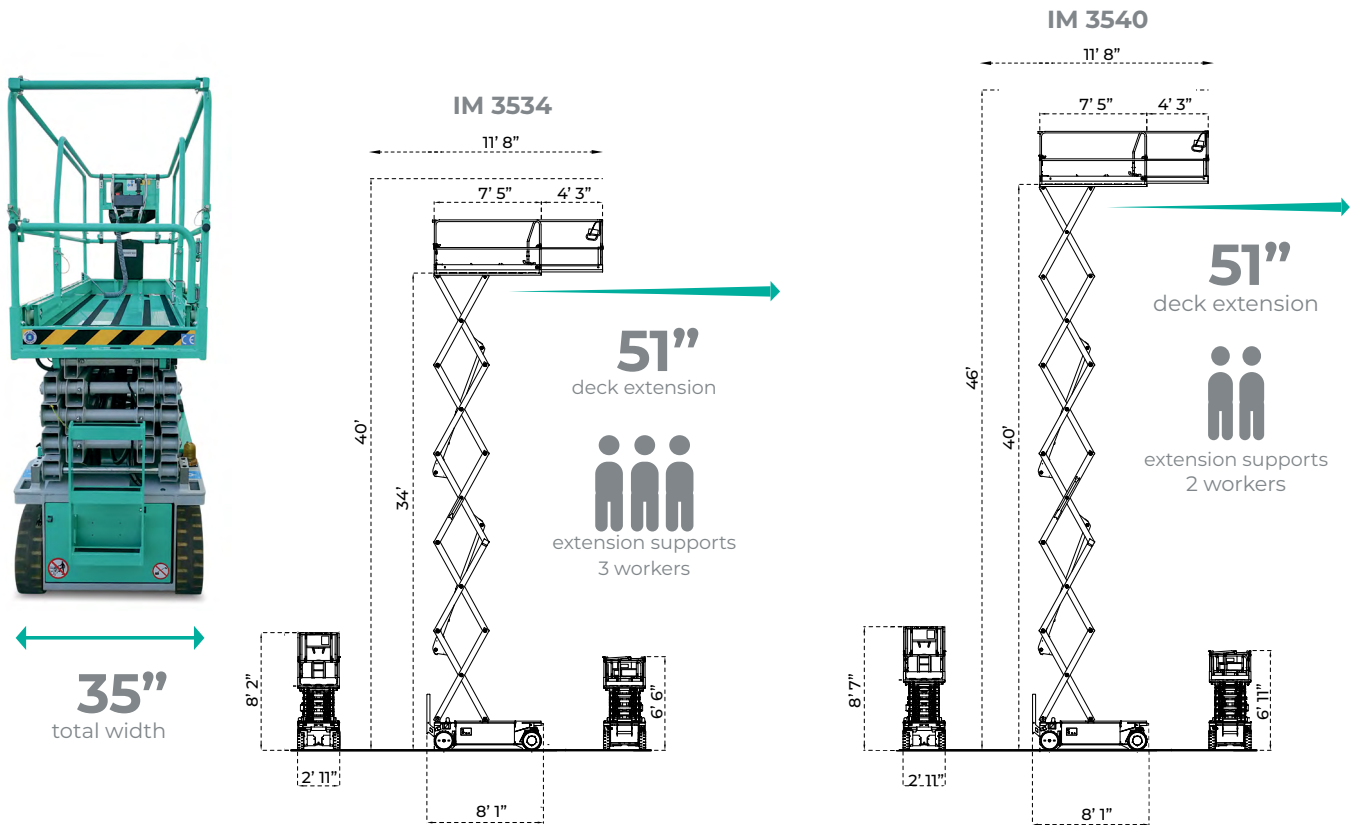

IM 35 SERIES	IM 3534		IM 3540	
Model #	1128496		1128506	
Platform height	33'	10,000 mm	40'	12,200 mm
Working height	39'	11,900 mm	46'	14,000 mm
Pot-hole (raised/lowered)	5" / 1"	123 mm / 24 mm	5" / 1"	123 mm / 24 mm
Height stowed	8' 2"	2,492 mm	8' 7"	2,619 mm
Height (ground to platform bottom)	4' 5.5"	1,362 mm	4' 10.5"	1,489 mm
Height storage (with guardrails)	6' 6"	1,985 mm	6' 11"	2,112 mm
Width (outside tires)	35"	892 mm	35"	892 mm
Platform length - extended	11' 8"	2,270 mm	11' 8"	2,270 mm
Platform length	7' 5"	230 kgs	7' 5"	230 kgs
Extension platform length	4' 3"	1300 mm	4' 3"	1300 mm
Capacity / number of people	660 lbs. / 3	300 kg / 3	510 lbs. / 2	230 kg / 2
Electric drive motors	24 V / 4.0 HP	24 / 3.0 kW	24 V / 4.0 HP	24 / 3.0 kW
Lifting power pack - hydraulic type	24 V / 4.0 HP	24 / 3.0 kW	24 V / 4.0 HP	24 / 3.0 kW
Battery (traction battery) C5	24V / 182Ah			
Battery charger	24V / 20A			
Hydraulic tank capacity	4.9 gal	17 l	4.9 gal	17 l
Drive speed	2.5 mph	4 km/h	2.5 mph	4 km/h
Safety traction	0.4 mph	0.6 km/h	0.4 mph	0.6 km/h
Gradeability	25%			
Internal steering radius	0'	0 m	0'	0 m
External steering radius	7' 2"	1.65 m	7' "	1.65 m
Tire size (wheel dimension)	16" x 5"	410 mm x 130 mm	16" x 5"	410 mm x 130 mm
Wheel type	Cushion			
Max side / longitudinal tilt angle	1.5 / 2.5°			
Total weight	6283 lbs.	2850 kg	7011 lbs.	3180 kg

IM 47 SERIES

ELECTRIC SCISSOR LIFTS



46'
working height

IM 4740



52'
working height

IM 4746



Standard AC power
to the platform



Standard cushioned
non-marking tires

OPTIONAL EQUIPMENT

- 120 V cable with plug, socket and safety cut-out (standard for US Models)
- Gel battery IM 47
- 2nd rotating beacon kit

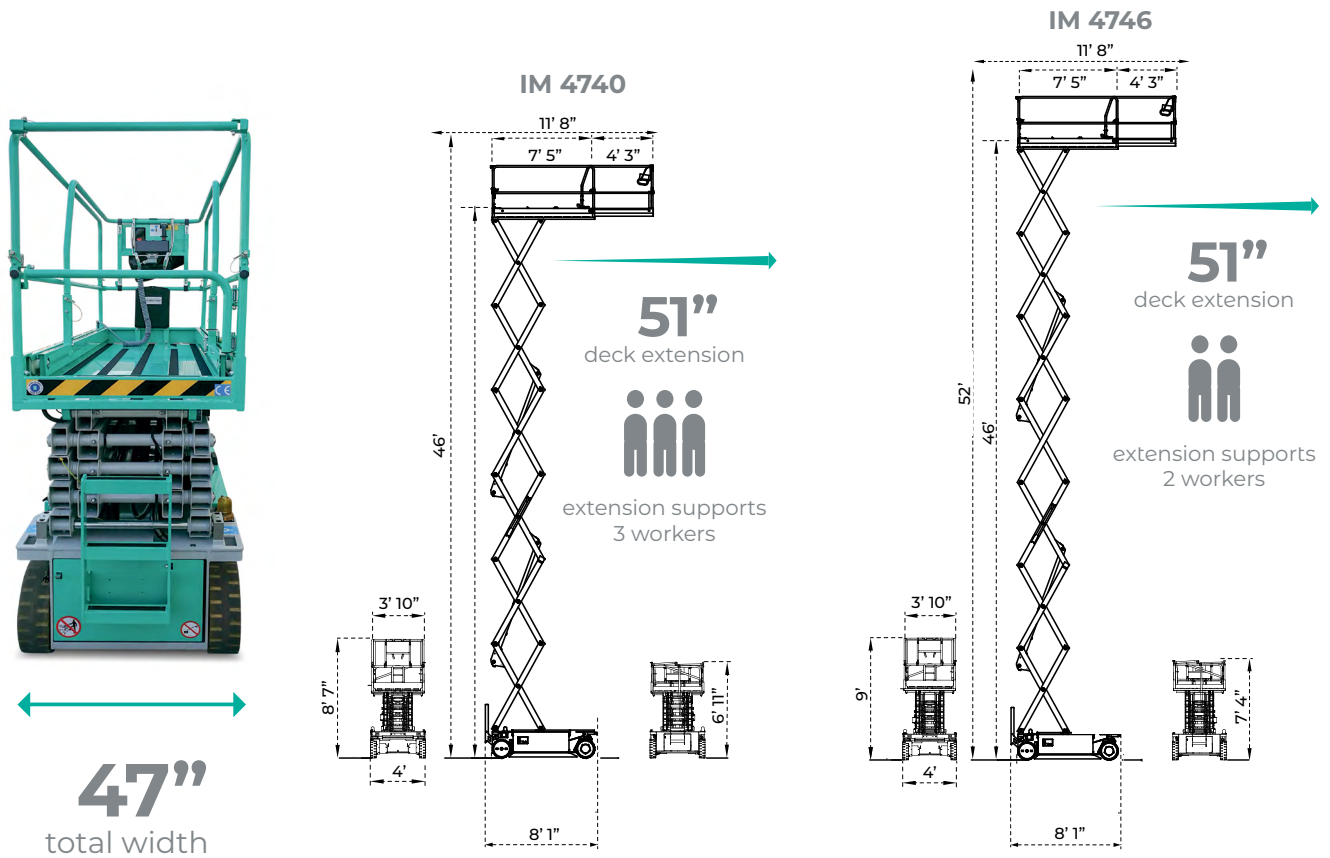

IM 47 SERIES		IM 4740		IM 4746	
Model #		1128556		1128566	
Platform height	39' 4"	12,000 mm		45' 7"	13,900 mm
Working height	45' 4"	13,800 mm		51' 7"	15,700 mm
Pot-hole (raised/lowered)	4.7" / 1"	120 mm / 22 mm		4.7" / 1"	120 mm / 22 mm
Height stowed	8' 7"	2,619 mm		9'	2,746 mm
Height (ground to platform bottom)	4' 11"	1,489 mm		5' 4"	1,616 mm
Height storage (with guardrails)	6' 11"	2,112 mm		7' 4"	2,239 mm
Width (outside tires)	3' 11" (4')	1,194 mm (1,228 mm)		3' 11" (4')	1,194 mm (1,228 mm)
Platform length - extended	11' 8"	3,570 mm		11' 8"	3,570 mm
Platform length	7' 5"	2,270 mm		7' 5"	2,270 mm
Extension platform length	4' 3"	1,295 mm		4' 3"	1,295 mm
Capacity / number of people	770 lbs. / 3	350 kgs / 3		550 lbs. / 2	250 kgs / 2
Electric drive motors	24 V / 4.0 HP	24 V / 3.0 kW		24 V / 4.0 HP	24 V / 3.0 kW
Lifting power pack - hydraulic type	24 V / 4.0 HP	24 V / 3.0 kW		24 V / 4.0 HP	24 V / 3.0 kW
Battery (traction battery) C5	24 V / 275 Ah	24 V / 275 Ah		24 V / 275 Ah	24 V / 275 Ah
Battery charger	24 V / 30 A	24 V / 30 A		24 V / 30 A	24 V / 30 A
Hydraulic tank capacity	4.9 gal	17 l		4.9 gal	17 l
Drive speed	2.5 mph	4 km/h		2.5 mph	4 km/h
Safety traction	0.4 mph	0.6 km/h		0.4 mph	0.6 km/h
Gradeability			25%		
Internal steering radius	0'	0 m		0'	0 m
External steering radius	9' 2 1/2"	2.35 m		9' 2 1/2"	2.35 m
Tire size (wheel dimension)	16" x 5"	410 mm x 130 mm		16" x 5"	410 mm x 130 mm
Wheel type			Cushion		
Max side / longitudinal tilt angle	1.8 / 3.0	1.8 / 3.0		1.2 / 2.0	1.2 / 2.0
Total weight	6,349 lbs.	2,880 kgs		6,548 lbs.	2,970 kgs

ROUGH TERRAIN SCISSOR LIFTS

ROUGH TERRAIN

SERIES IM RT SCISSOR LIFTS



IMER's Rough Terrain Scissor Lifts lead the industry with innovative technologies as a direct result of years of experience, concentrated research, and a goal to provide superior products that deliver unparalleled productivity and safety.

The IMER IM RT Series are customizable with AC electric or diesel / electric engines. Ideal for any terrain and the perfect solution for outdoor and indoor use.

Engineered to allow operators to drive in any position, including at full height, providing superior productivity.

The IM RT Series scissors ensure the maximum capacity in both the platform and on the manual deck extension. They offer traction and stability at maximum height, even with multiple workers safely working on the fully extended platform.

In addition to the standard features and accessories, IMER Group has developed **IMERVIEW**, a GPS system which makes it possible to monitor and/or control aerial machines remotely in real time.

This invaluable tool will allow rental companies or dealers to manage every machine in their fleet through a dashboard, while gathering reports for machine performance and maintenance, accounting, billing, and more.

PRODUCT RANGE

[IM 7043 RT DE & E](#)

[IM 8747 RT E & D](#)

[IM 8756 RT E & D](#)

STANDARD EQUIPMENT

- Manual deck extension (full capacity on extension deck)
- Auto-leveling hydraulic stabilizers
- Front wheel steering
- Hydraulic transmission 4WD
- Oscillating front axle
- Negative parking brakes
- Free wheel device
- Manual emergency lowering device
- Proportional controls
- Multi-function indicator on upper control box includes hour meter / battery charge indicator and fault code indicator
- Cylinder holding valves
- Manual deck extension 59 in (1.5 m)
- Tilt sensor with motion cut out and alarms
- Load sensor
- Motion alarm (travel and elevated)
- Rough terrain tires extra grip non-marking
- Removable control box
- Inward fold down railings
- Flashing beacon
- 120 V cable with plug socket and safety cut-out



BI-ENERGY DIESEL / ELECTRIC POWER

The IMER IM RT diesel / electric engine model can operate on Electric only, or Diesel only, making it two lifts in one.



The **SERIES IM RT** scissor lifts are the ideal solution in the cases requiring:

- **Rough terrain**
- **High productivity - multiple workers**
- **Hard-to-reach spaces**
- **Indoor / outdoor use** - construction: plumbing, electrical, and HVAC installation, industrial logistics, maintenance



PERFORMANCE VERSATILITY

The remarkable size and length of the platform and the extension provides increased performance. Support multiple workers and tools on the extended platform - extending further than competitive lifts. Work and drive safely at maximum height and at full load with no capacity restrictions.



4WD / ROUGH TERRAIN CAPABILITY

Massive 28" extra grip rough terrain tires, oscillation front axle and an impressive 35% gradeability.

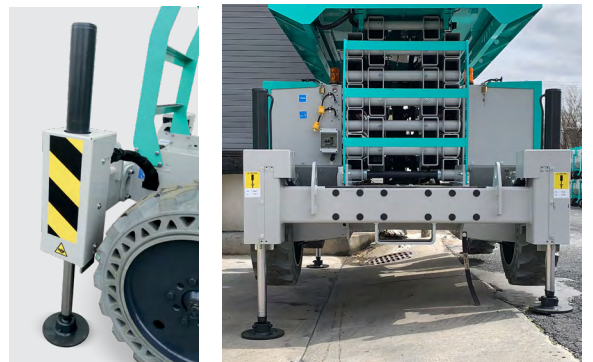

AUTOMATED TECHNOLOGY

Automatic hydraulic stabilization system levels the machine on gravel and steep slopes.

IM 7043

ELECTRIC & DIESEL-ELECTRIC SCISSOR LIFTS

OUTDOOR AND INDOOR USE

ELECTRIC EQUIPMENT

- AC Motor 48V-7.2kW
- Traction Battery 48V 300Ah (C5)
- Battery charger with automatic switch off
- Battery control system with low voltage cut-out protection
- Battery cut-out handle
- Rough terrain tires extra grip non-marking 28" X 9 1/2" (720x245 mm)

DIESEL-ELECTRIC EQUIPMENT

- Yanmar water cooled diesel engine
- Start-up battery 12V 66Ah
- Start-up battery alternator
- AC Motor 48V-7.2kW
- Traction Battery 48V 300Ah (C5)
- Battery charger with automatic switch off
- Battery control system with low voltage cut-out protection
- Battery cut-out handle
- Rough terrain tires extra grip non-marking 28" X 9 1/2" (720x245 mm)

OPTIONAL EQUIPMENT

- Rough terrain black tires



IM 7043



Plug unit for battery charger and power supply on basket with battery level indicator (E and DE versions)

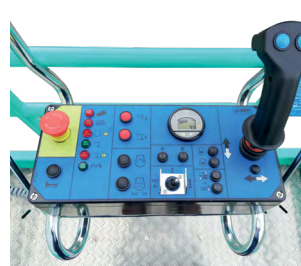

Simple and intuitive control box that can be removed from the basket for loading / unloading the machine



Best in class 40° steering

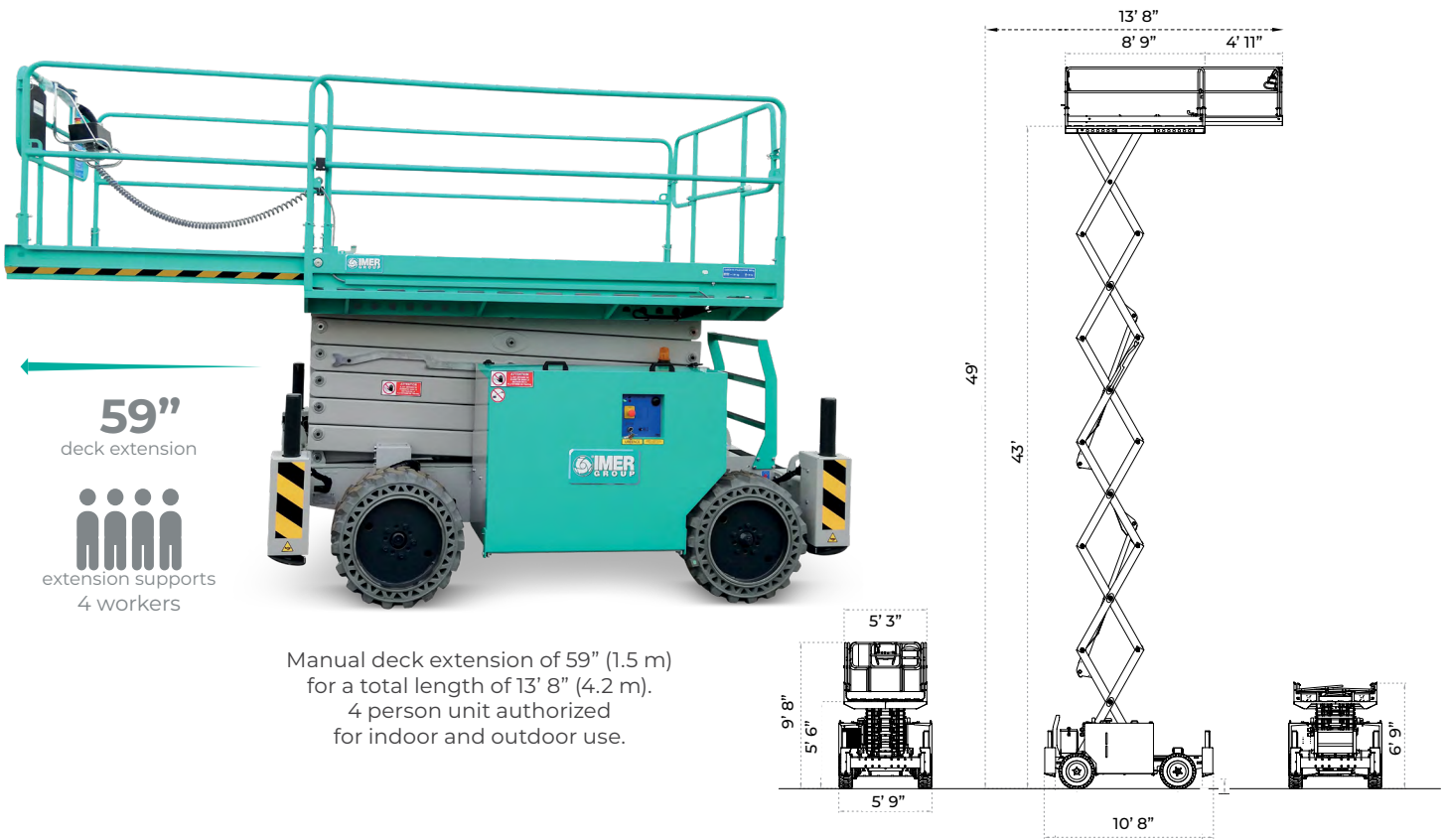

Manual deck extension of 59" (1.5 m)
for a total length of 13' 8" (4.2 m).
4 person unit authorized
for indoor and outdoor use.

IM 7043	IM 7043 RT E		IM 7043 RT DE	
Model #	1128676		1128696	
Platform height	43'	12,800 mm	43'	12,800 mm
Working height	49"	14,900 mm	49"	14,900 mm
Pot-hole (raised/lowered)	12"	300 mm	12"	300 mm
Height stowed	6' 9"	2,056 mm	6' 9"	2,056 mm
Height (ground to platform bottom)	5' 6"	1,698 mm	5' 6"	1,698 mm
Height storage (with guardrails)	9' 8"	2,944 mm	9' 8"	2,944 mm
Width (outside tires)	5' 11"	1,800 mm	5' 11"	1,800 mm
Platform length - extended	13' 8"	4,200 mm	13' 8"	4,200 mm
Platform length	8' 9"	2,700 mm	8' 9"	2,700 mm
Extension platform length	4' 11"	1,500 mm	4' 11"	1,500 mm
Capacity (stabilized)* / number of people	882 lbs. / 4 (1,100 lbs. / 4)	400 kgs / 4 (500 kgs / 4)	882 lbs. / 4 (1,100 lbs. / 4)	400 kgs / 4 (500 kgs / 4)
Min. height (chassis to ground)	12"	300 mm	12"	300 mm
Electric drive motors	48 V / 10 HP	48 V / 7.2 kW	48 V / 10 HP	48 V / 7.2 kW
Diesel engine - Yanmar	N/A	N/A	25 HP	18.8 kW
Lifting power pack (hydraulic)	48 V / 3 HP	48 V / 2.1 kW	48 V / 3 HP	48 V / 2.1 kW
Lifting / lowering time (loaded)	36 sec (35 sec)	36 sec (35 sec)	36 sec (35 sec)	36 sec (35 sec)
Battery charger	48 V / 30 A			
Hydraulic tank capacity	14.8 gal	56 l	14.8 gal	56 l
Drive speed	2.5 mp/h	4 km/h	3.4 mp/h	5.5 km/h
Safety traction	0.4 mp/h	0.6 km/h	0.4 mp/h	0.6 km/h
Internal steering radius	5' 7"	1.94 m	5' 7"	1.94 m
External steering radius (without stabilizers)	15' 10"	4.83 m	15' 10"	4.83 m
	14' 10"	4.52 m	14' 10"	4.52 m
Gradeability	2WD: 25% / 4WD: 35%	2WD: 25% / 4WD: 35%	2WD: 25% / 4WD: 35%	2WD: 25% / 4WD: 35%
Tire size (wheel dimension)	28" x 9 1/4"	720 mm x 245 mm	28" x 9 1/4"	720 mm x 245 mm
Max side / longitudinal tilt angle	2.0 / 2.5	2.0 / 2.5	2.0 / 2.5	2.0 / 2.5
Total weight	10,471 lbs.	4,750 kgs	10,802 lbs.	4,900 kgs

* 2 people for outdoor use with non-stabilized platform

IM 87 SERIES

ELECTRIC & DIESEL-ELECTRIC SCISSOR LIFTS



OUTDOOR AND INDOOR USE

STANDARD ELECTRIC EQUIPMENT

- AC Motor 48V-15kW
- Traction Battery 48V 630Ah
- Battery charger with automatic switch off
- Battery control system with low voltage cut-out protection
- Battery cut-out handle
- Rough terrain tires extra grip non-marking 33"

STANDARD DIESEL EQUIPMENT

- Yanmar water cooled diesel engine
- Start-up battery 24V 65Ah
- Start-up battery alternator

OPTIONAL EQUIPMENT

- Rough terrain black tires

IM 8756

IM 8747



A/C electric power unit

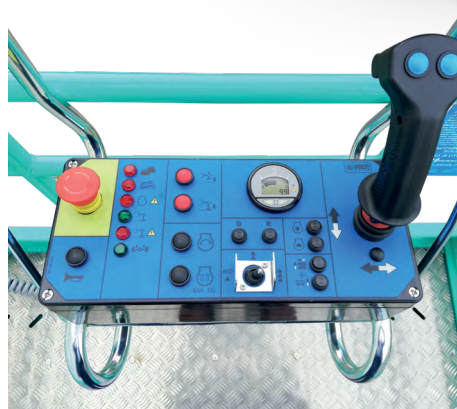

Simple and intuitive control box that can be removed from the basket for loading / unloading the machine

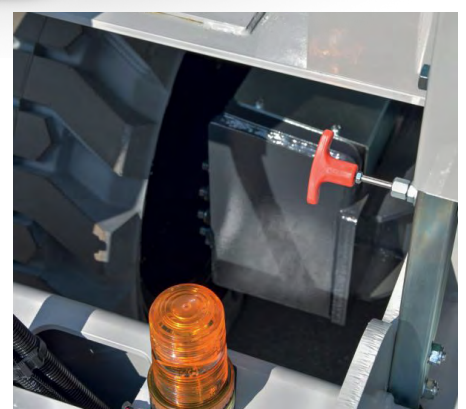

Emergency descent control handle

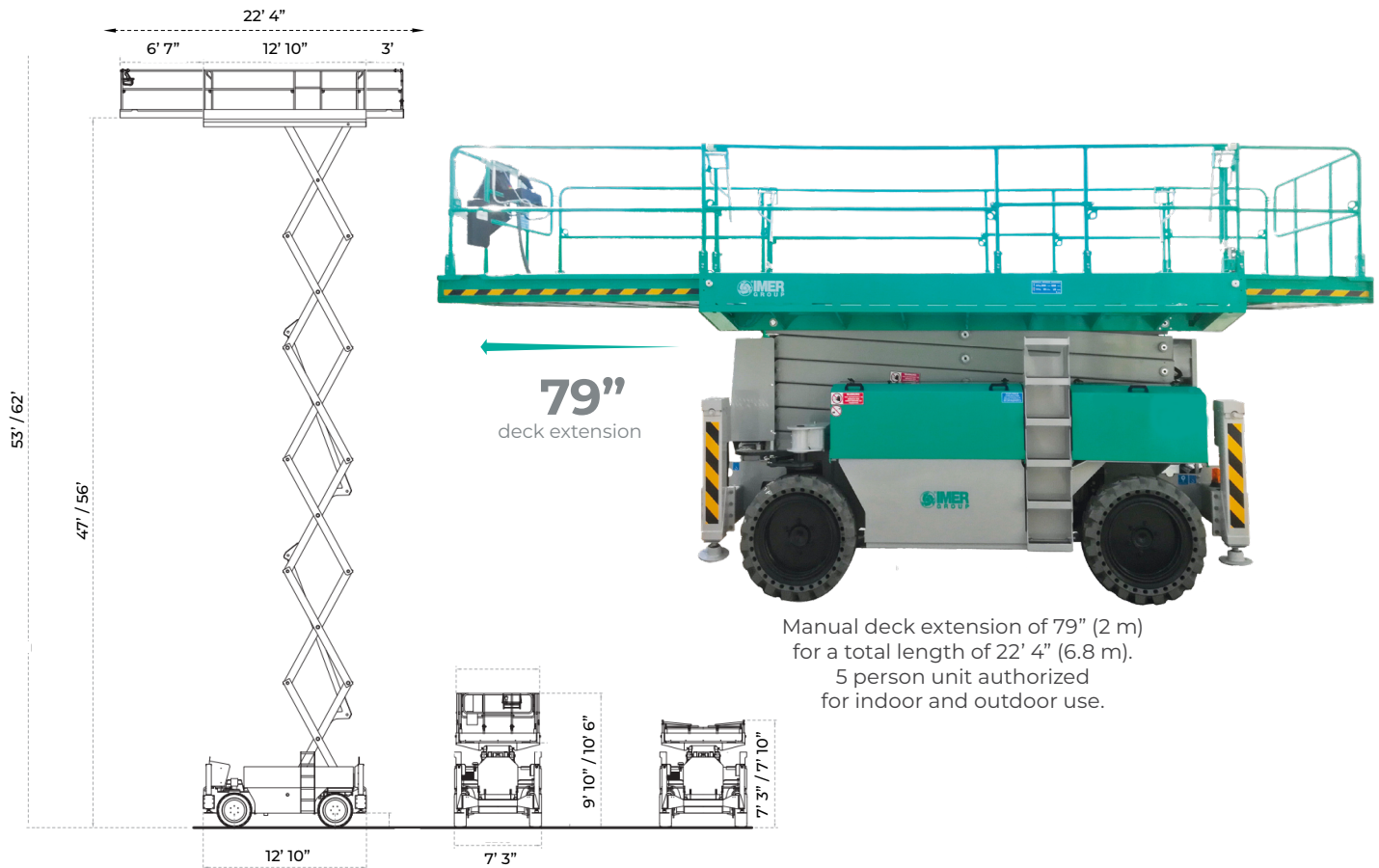

IM 87 SERIES	IM 8747		IM 8756	
Model #	1128701		1128702	
Platform height	47'	14,200 mm	56'	17,00 mm
Working height	53'	16,200 mm	62'	18,900mm
Height stowed	9' 10"	3010 mm	10' 6"	3200 mm
Storage height	7' 3"	2,215 mm	7' 10"	2,400 mm
Max drive height	full			
Facultative stabilizers use	up to max height			
Capacity with stabilized platform	1,763 lbs. / 6	800 kg / 6	1,190 lbs. / 6	540 kg / 6
Capacity with non-stabilized platform	1,763 lbs. / 3	800 kg / 3	1,190 lbs. / 3	540 kg / 3
Diesel Engine	31 HP	23 kW	31 HP	23 kW
AC electric motor	20 HP	15 kW	20 HP	15 kW
Traction battery	48 V / 630 Ah	48 V / 630 Ah	48 V / 630 Ah	48 V / 630 Ah
Battery charger	48 V / 55 A	48 V / 55 A	48 V / 55 A	48 V / 55 A
Hydraulic tank capacity	26 gal	100 l	26 gal	100 l
Max. speed	D: 3.7 mph E: 2 mph	D: 6 Km/h E: 3.3 Km/h	D: 3.7 mph E: 2 mph	D: 6 Km/h E: 3.3 Km/h
Safety speed	.4 mph	.6 Km/h	.4 mph	.6 Km/h
Lift/Lower time	70 sec			
Gradeability	D: 40% E: 30%			
Internal turning radius	2' 7"	800 mm	2' 7"	800 mm
External turning radius	13' 9"	4,200 mm	13' 9"	4,200 mm
Tire size	28" x 11"	815 x 295 mm	28" x 11"	815 x 295 mm
Weight	D: 17,256 lbs. E: 18,210 lbs.	D: 7,950 kg E: 8,260 kg	D: 18,298 lbs. E: 18,959lbs.	D: 8,300 kg E: 8,600 kg

* 2 people for outdoor use with non-stabilized platform

IM R SERIES TRACKED CRAWLER BOOMS

TRACK DRIVEN

SERIES IM R ARTICULATED & TELESCOPIC LIFTS

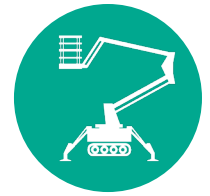

IMER was one of the first companies to introduce tracked aerial units to the international market years ago.

In compliance with strict European safety standards, the IM R Series was engineered with safety features that far exceeded Western regulations of that time.

While the IM R Series was first engineered with safety in mind, user experience, maneuverability, and versatility were also a priority.

The IM R Series is an easy to operate, compact and lightweight solution for maximum clearance and versatility. The reduced size of the units and portable remote controls ensure maneuverability in tight spaces while providing added operator safety. In addition, track-driven capabilities offer maximum versatility for both outdoor and indoor applications.

Like IMER's scissor lift series, the IM R Series share innovative technologies and a commonality of parts, which simplifies maintenance and improves parts costs and accessibility. In addition to the standard features and accessories, IMER Group has developed **IMERVIEW**, a GPS system which makes it possible to monitor and/or control aerial machines remotely in real time.

PRODUCT RANGE

[SERIES IM R 23 DA](#)

[SERIES IM R 19](#)

[SERIES IM R 15 DA](#)

[SERIES IM R 13 T](#)

STANDARD EQUIPMENT

- Automatic outrigger leveling system
- 355° rotation (non-continuous)
- Electric motor for indoor use
- Air and Water connections to the platform
- 120V AC power to platform
- Removable wireless control box
- Tether for wired connectivity
- Emergency hand pump
- Cylinder holding valve
- Hour meter
- Load and tip detection sensor
- Load cell
- Hydraulic jib
- Rubber tracks
- Variable travel speeds
- Remote battery charger
- Removable basket with 1 pin detach
- Overload sensor
- 120V battery charger
- Proportional controls with diagnostics
- Honda GX engine or Yanmar diesel
- Hydraulically adjustable track width
- Hydraulic basket rotation - 124° (except IM R 13 T)



UNMATCHED ACCESSIBILITY

The IM R Tracked Series allows you to go where no towable or self-driven lifts can go and easily access those hard-to-reach areas. With a remarkable extension height, side outreach and 355° rotation, the IM R Series offers unmatched accessibility as well.

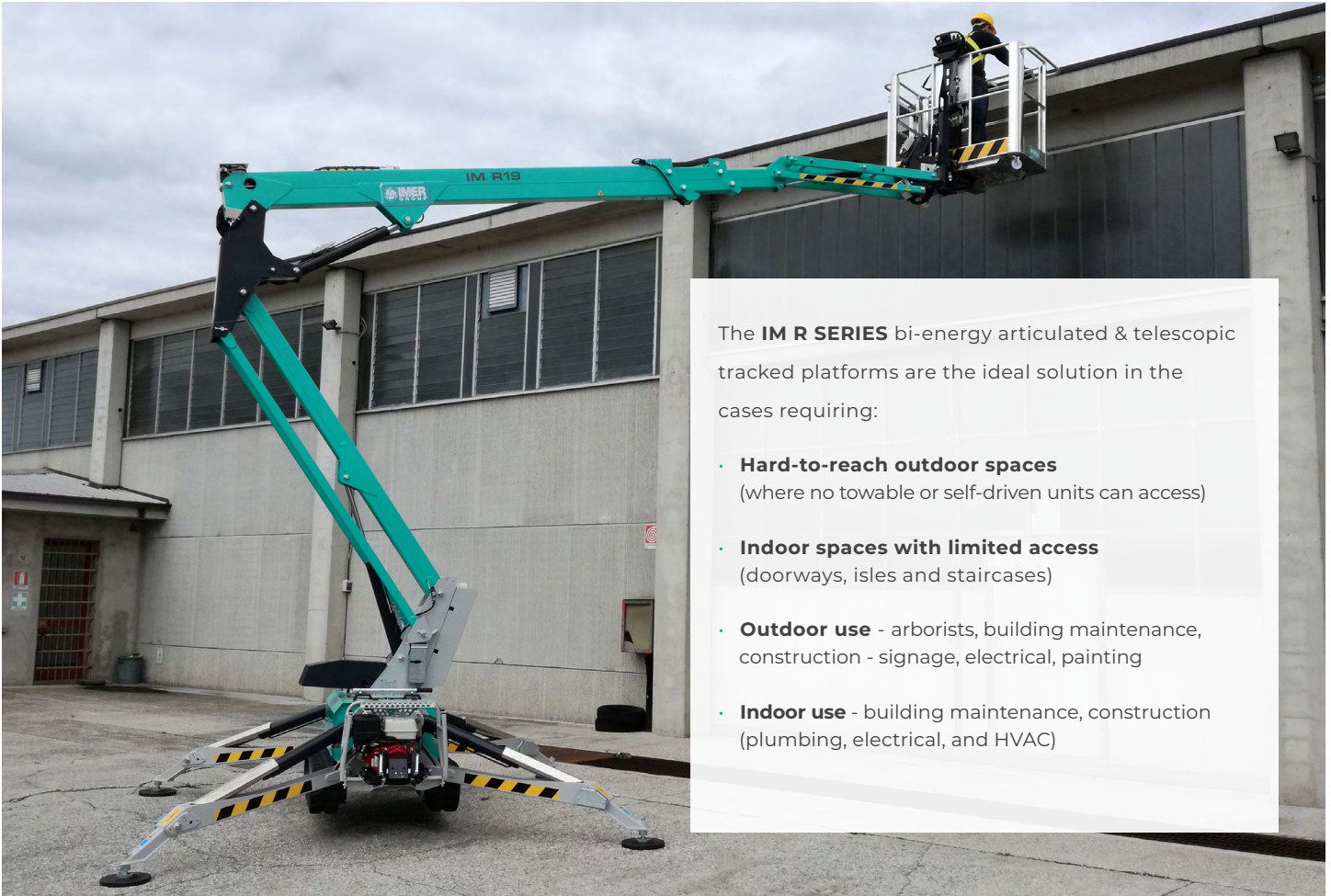

The **IM R SERIES** bi-energy articulated & telescopic tracked platforms are the ideal solution in the cases requiring:

- **Hard-to-reach outdoor spaces**
(where no towable or self-driven units can access)
- **Indoor spaces with limited access**
(doorways, isles and staircases)
- **Outdoor use** - arborists, building maintenance, construction - signage, electrical, painting
- **Indoor use** - building maintenance, construction (plumbing, electrical, and HVAC)



FAST & SECURE LEVELING

Automatic outrigger leveling system for quick set up and peace of mind.



EASY USER EXPERIENCE

A user-friendly control panel. The easily removable remote controlled unit allows for more space available in the basket and navigating from the ground.

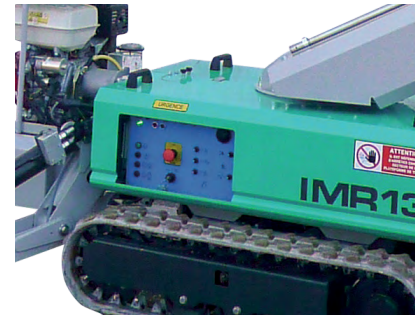

EASY ACCESS

In addition to the removeable control box in the basket, the IM R Series includes an easy to access ground control panel.

IM R 23

ATRIUM LIFT DOUBLE ARTICULATED

OUTDOOR AND INDOOR USE

STANDARD EQUIPMENT

- Automatic outrigger leveling system
- 355° rotation (non-continuous)
- 120V, 16 amp electric motor for indoor use
- Air / Water outlet in the platform basket
- 120V AC power to platform
- Removable wireless control box
- Tether for wired connectivity
- Max 510 lbs. in basket (two person capacity)
- Two travel speeds
- Emergency hand pump
- Cylinder holding valve
- Hour meter
- Load and tip detection sensor
- Hydraulic jib
- Rubber tracks
- Remote battery charger
- Removable basket with 1 pin detach
- Overload sensor
- 120V battery charger
- Proportional controls with diagnostics
- Honda iGX800 Engine
- Hydraulically adjustable track width
- 8" outrigger pads
- Hydraulic basket rotation - 124°

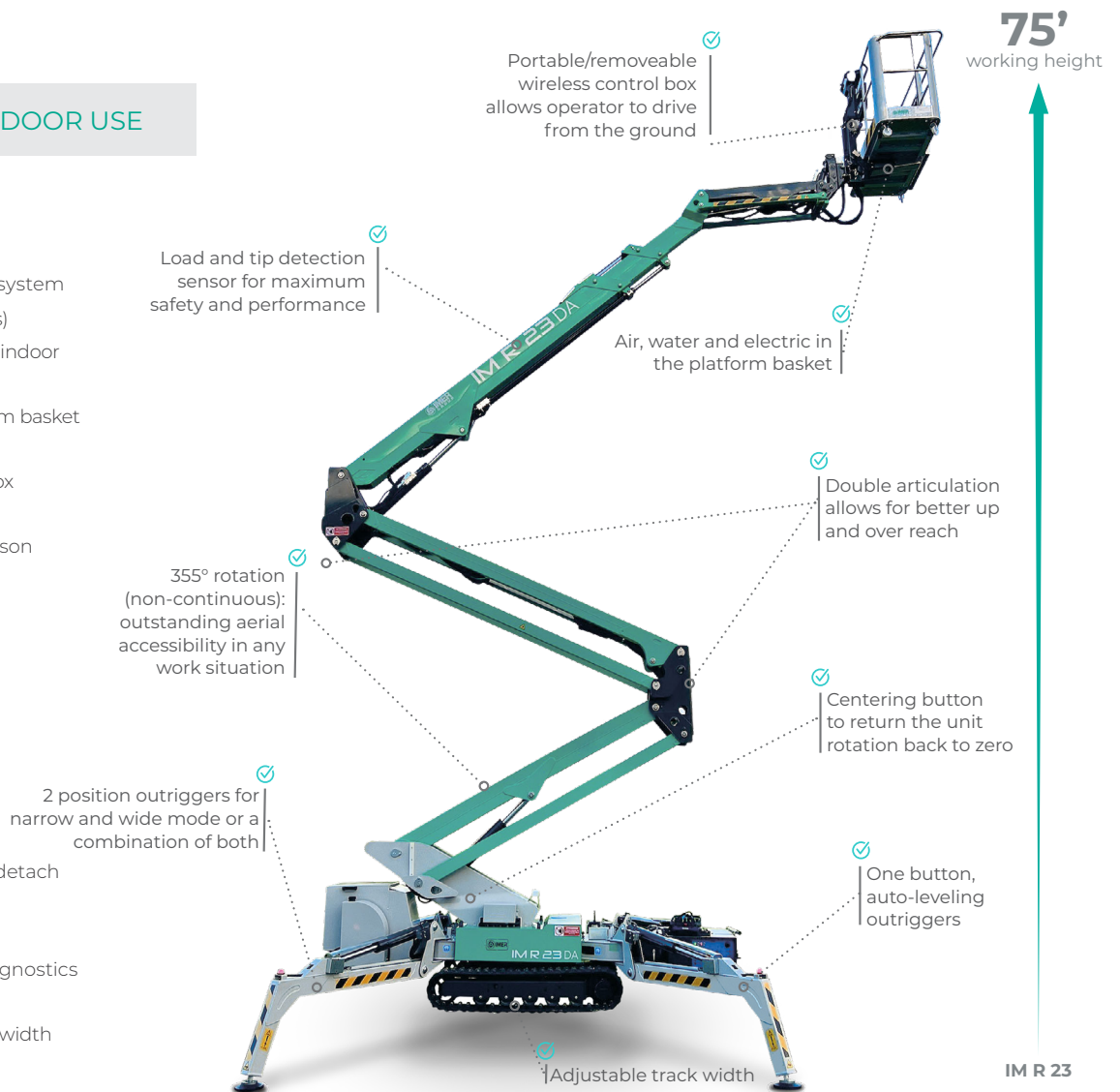

OPTIONAL EQUIPMENT

- Non-marking rubber tracks
- Working light in the platform basket
- 12 V emergency pump
- 14" Oversized outrigger pads
- Kubota 3TNV70 Diesel Engine
- Wireless radio-control box
- IMERVIEW GPS Remote Monitor System
- Lithium option
- Single man basket

IM R 23		
Model # (Diesel)	1128632 (1128633)	
Working height	75'	23m
Platform height	69'	21m
Side outreach (weight in basket)	35' / 507 lbs. - 39' / 308 lbs.	10.6m / 230kg - 12m / 140kg
Rotation (non-continuous)	355°	
Basket dimensions	54" x 30" x 42"	1.4 mm x 0.75 mm x 1.1 mm
Basket rotation	124°	
Transport length (without basket)	18' 8" (4' 2")	5.7m (4.95m)
Transport width (without basket)	Max 3' 3" (4' 2")	Max .98m (1.28m)
Height in stowed position	6' 6"	1.99m
Overall outrigger footprint	12' 9" x 12' 1"	3.
Stabilizer load	3930 psf	1750 daN
Driving speed	0 - 1.7 mph	0 - 2.8 km/h
Gradeability	32%	
Platform capacity	510 lbs.	231 kg
Honda iGX800	25 hp	18 kW
Diesel 3TNV70 (optional)	23 hp	17 kW
Machine weight (diesel)	6525 lbs. (6613 lbs.)	2960kg (3000kg)



Standard emergency hand pump with ease of access and operation.



Compact jib assembly hosting both the load sensor and basket rotation system.



Hydraulically adjust the track width for added stability and traction.

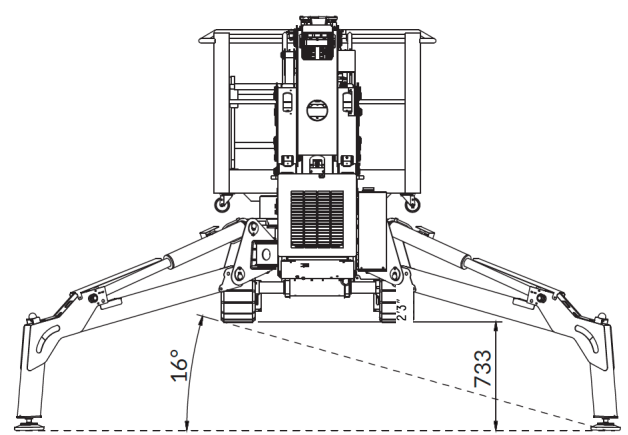
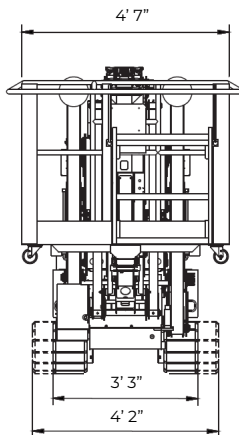
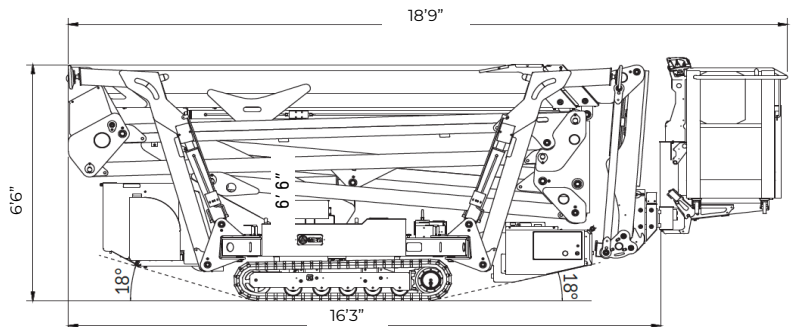
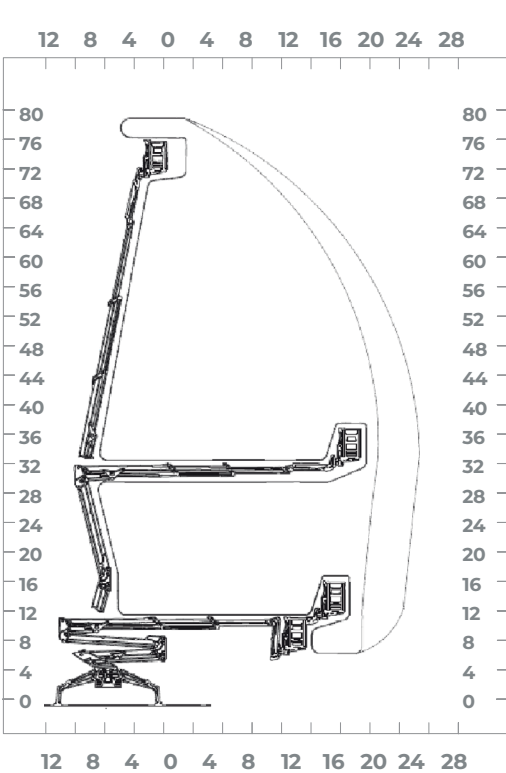

IM R 19

ATRIUM LIFT SINGLE ARTICULATED

OUTDOOR AND INDOOR USE

STANDARD EQUIPMENT

- Automatic outrigger leveling system
- 355° rotation (non-continuous)
- Hydraulic basket rotation - 124°
- 120V, 15 amp electric motor for indoor use
- Air / Water outlet in the platform basket
- 120V AC power to platform
- Removable wireless control box
- Tether for wired connectivity
- Max 510 lbs. in basket (two person capacity)
- Three travel speeds
- Emergency hand pump
- Cylinder holding valve
- Hour meter
- Load and tip detection sensor
- Load cell
- Hydraulic jib
- Rubber tracks
- Remote battery charger
- Removable basket with 1 pin detach
- Overload sensor
- 120V battery charger
- Honda iGX390 engine
- Hydraulically adjustable track width
- Proportional controls with diagnostics

62'
working height

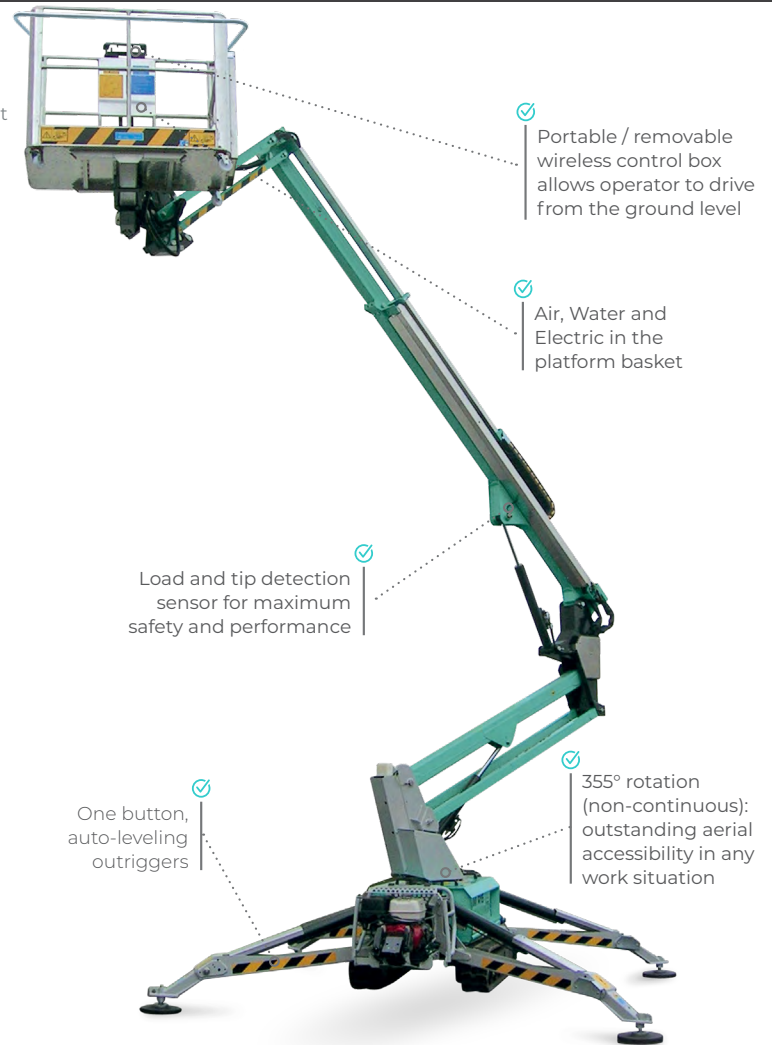

IM R 19

OPTIONAL EQUIPMENT

- Non-marking rubber tracks
- Working light in the platform basket
- 12 V emergency pump
- 120 V desktop remote charge
- Sliding, oversized outrigger shoes
- Oversized outrigger pads
- Double speed traction
- Aluminum basket (2' 11-1/2" x 2' 5")
- Aluminum basket (4' 7" x 2' 3-1/2")
- IMERVIEW GPS Remote Monitor System
- Lithium option
- Yanmar L100N diesel engine

IM R 19

Model # (Lithium)	1128770 (1128772)	
Working height	62'	19 m
Platform height	56'	17 m
Side outreach (weight in basket)	32' / 176 - 28' / 310 - 23' / 510 ft / lbs.	9.75 / 80 - 8.5 / 120 - 7 / 227 m / kg
Rotation (non-continuous)	355°	
Basket dimensions	57" x 28" x 43"	1448 x 711 x 1092 mm
Basket rotation	124°	
Transport length (without basket)	17' 5" / 15' 2"	5308 / 4622 mm
Transport width (without basket)	Max 3' 6" / Min 2' 7"	Max 1066 / Min 787 mm
Height in stowed position (w/ stabilizers in position)	Min 6' 6" / Max 6' 11"	Min 1981 / Max 2108 mm
Overall outrigger footprint	10' 10" x 10' 11"	3302 x 3327 mm
Stabilizer load	3930 psf	1750 daN
Driving speed	0 - 1.25 mph	0 - 2 km / h
Gradeability	32%	
Electric pump	120 V / 1.5 HP	120 V / 1.125 kW
Max. hydraulic pressure	3190 psi	220 bar
Battery	12V	
Battery charger (Lithium)	12 V / (48 V)	
Honda GX390	13 hp	9.7 kW
Diesel L100N (optional)	8.9 hp	6.6 kW
Machine weight (Lithium)	5370 (5445) lbs.	2435 (2470) kg

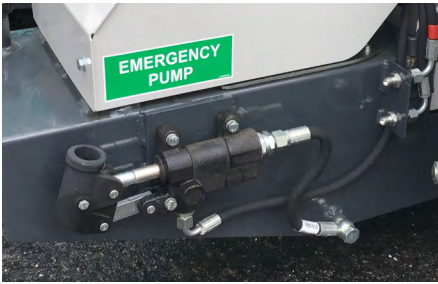

Standard emergency hand pump with ease of access and operation.



Compact jib assembly hosting both the load sensor and basket rotation system.



Hydraulically adjust the track width for added stability and traction.



Compact width allows access in narrow, hard to reach places



Easy access both outdoor and indoor. Non-marking tracks for indoor use

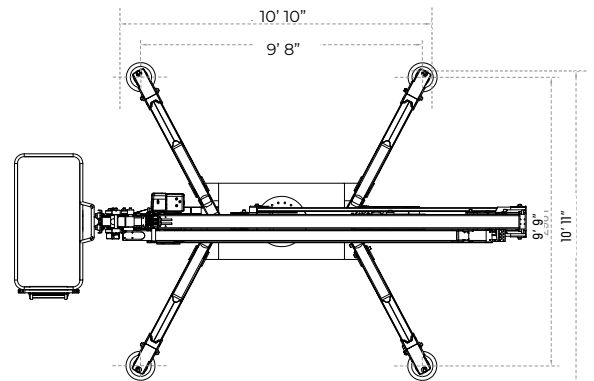
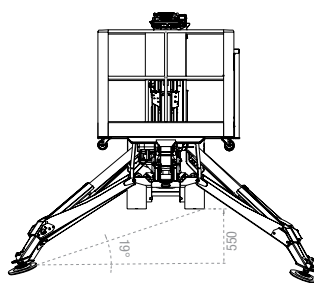
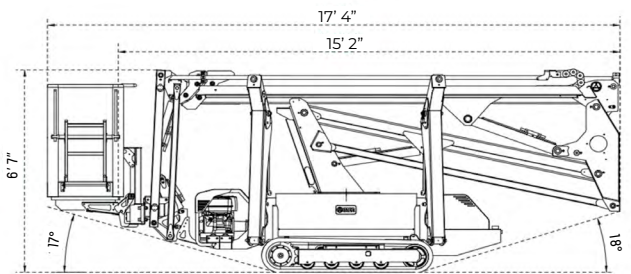
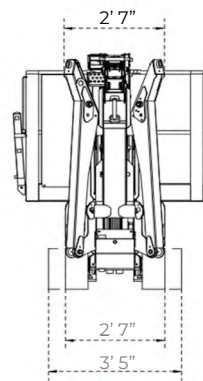
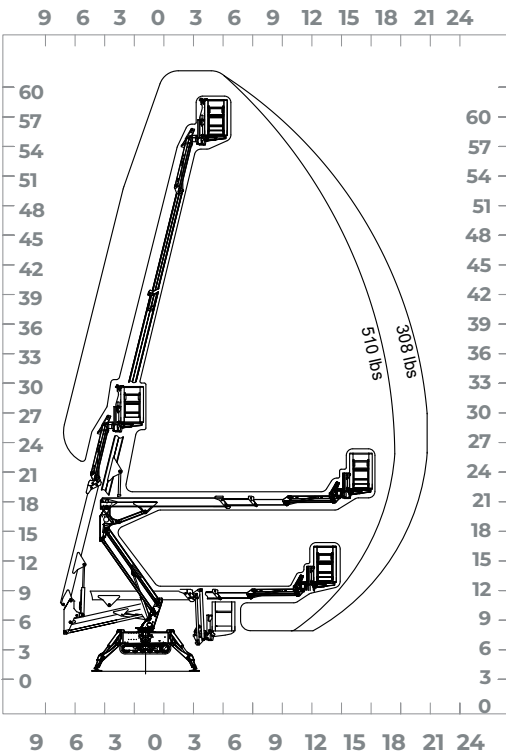

IM R 15 DA

ATRIUM LIFT DOUBLE ARTICULATED

OUTDOOR AND INDOOR USE

STANDARD EQUIPMENT

- Automatic outrigger leveling system
- 355° rotation (non-continuous)
- Hydraulic basket rotation - 124°
- 120V, 15 amp electric motor for indoor use
- Air / Water outlet in the platform basket
- 120V AC power to platform
- Removable wireless control box
- Tether for wired connectivity
- Max 510 lbs. in basket (two person capacity)
- Three travel speeds
- Emergency hand pump
- Cylinder holding valve
- Hour meter
- Load and tip detection sensor
- Load cell
- Hydraulic jib
- Rubber tracks
- Remote battery charger
- Removable basket with 1 pin detach
- Overload sensor
- 120V battery charger
- Honda iGX390 engine
- Hydraulically adjustable track width
- Proportional controls with diagnostics

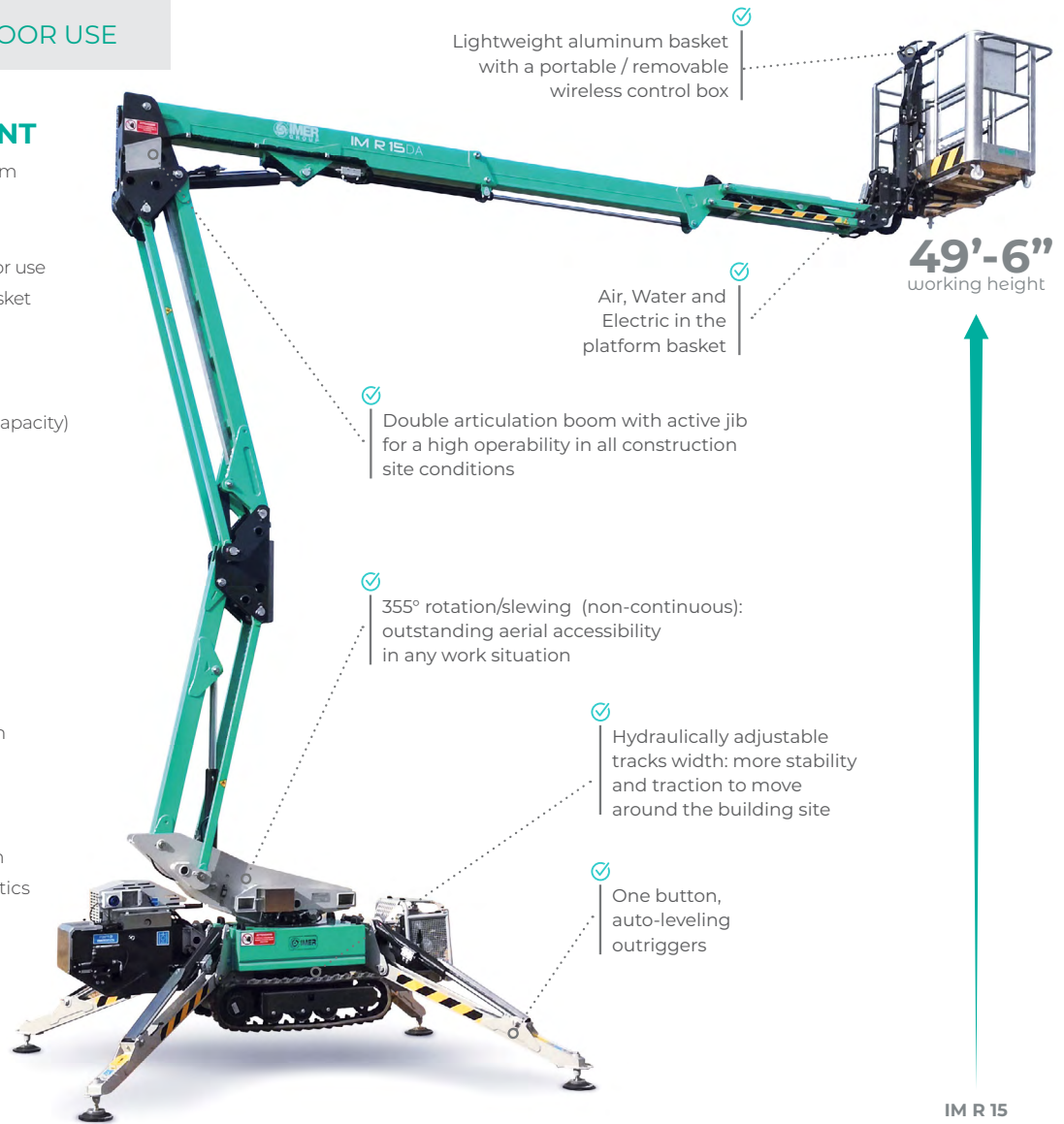

OPTIONAL EQUIPMENT

- Non-marking rubber tracks
- Working light in the platform basket
- 12 V emergency pump
- 120 V desktop remote charge
- Sliding, oversized outrigger shoes
- Oversized outrigger pads
- Double speed traction
- Aluminum basket (2' 11-1/2" x 2' 5")
- Aluminum basket (4' 7" x 2' 3-1/2")
- IMERVIEW GPS Remote Monitor System

IM R 15

IM R 15		
Model # (Lithium)	1128759 (1128760)	
Working height	49' 6"	15.10 m
Platform height	43'	13.10 m
Side outreach (weight in basket)	23' / 506 lbs.	7.00 m / 230 kgs
Rotation (non-continuous)	355°	355°
Basket dimensions	57" x 27 1/2" x 43"	1.40 m x 0.70 m x 1.10 m
Basket rotation	124°	
Transport length (without basket)	14' 5" / 12'	4.40 m (3.65 m)
Transport width (without basket)	Min: 2' 7" / Max: 3' 5"	Min: 0.79 m / Max: 1.06 m
Height in stowed position	Min: 6' 6" / Max: 6' 11"	Min: 1.99 m / Max: 2.05 m
Overall outrigger footprint	9' 6" x 10'	2.92 m x 3.08 m
Stabilizer load	3,930 lbs.	30%
Driving speed	1.12 mph	1.8 km/h
Gradeability	32%	
Platform capacity	510 lbs.	230 kgs
Honda GX390	13 hp	9.7 kW
Diesel L100N (optional)	8.9 hp	6.6 kW
Lithium Electric Motor (optional)	48 V / 5.4 hp AC	48 V / 4 kW AC
Machine weight (Lithium)	4,475 lbs. (4,550 lbs.)	2,030 kg (2,064 kg)

*w/ stabilizers in position



Outstanding accessibility with a 355° rotation (non-continuous) and 124° jib rotation



A Honda Engine and Electric Motor provide a bi-energy solution, allowing both indoor and outdoor use



Lightweight aluminum basket options available for one or two operators



Compact 31" width allows access in narrow, hard to reach places



Easy access both outdoor and indoor. Non-marking tracks for indoor use - transport width is 41" with the tracks extended

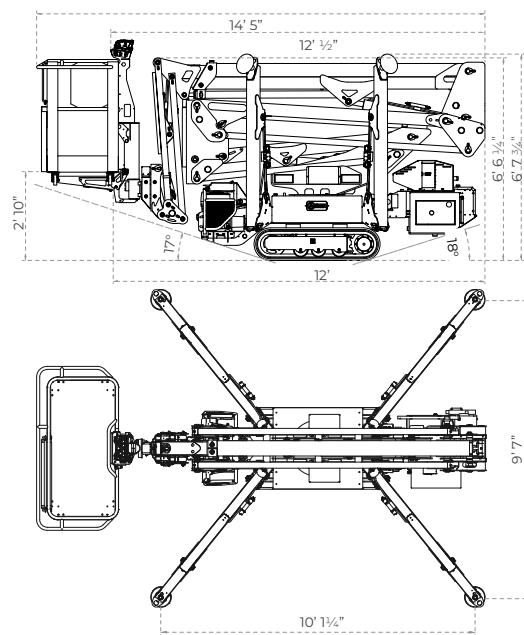
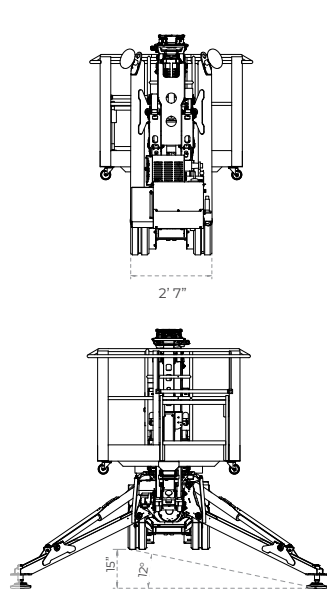
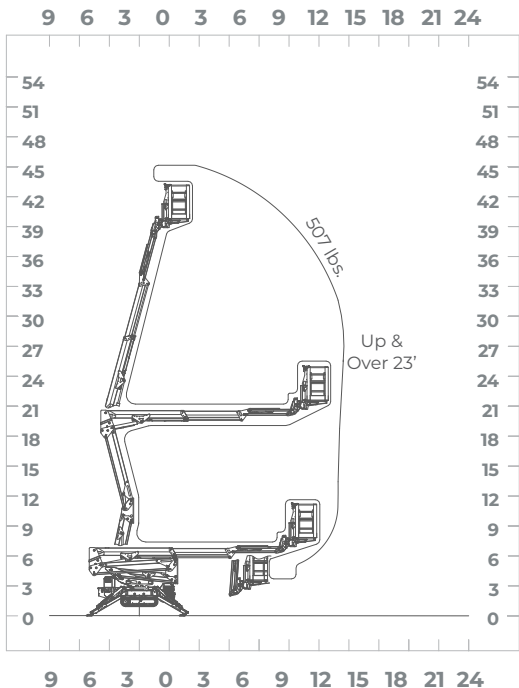

IM R 13 T

ATRIUM LIFT TELESCOPIC

OUTDOOR AND INDOOR

STANDARD EQUIPMENT

- Automatic outrigger leveling system
- 120V, 15 amp electric motor
- Air / Water outlet in the platform basket
- 120V AC power to platform
- Removable wireless control box
- Tether for wired connectivity
- Emergency hand pump
- Cylinder holding valve
- Hour meter
- Load and tip detection sensor
- Load cell
- Hydraulic jib
- Rubber tracks
- Remote battery charger
- Removable basket with 1 pin detach
- Overload sensor
- 120V battery charger
- Proportional controls with diagnostics
- Honda GX390 Engine

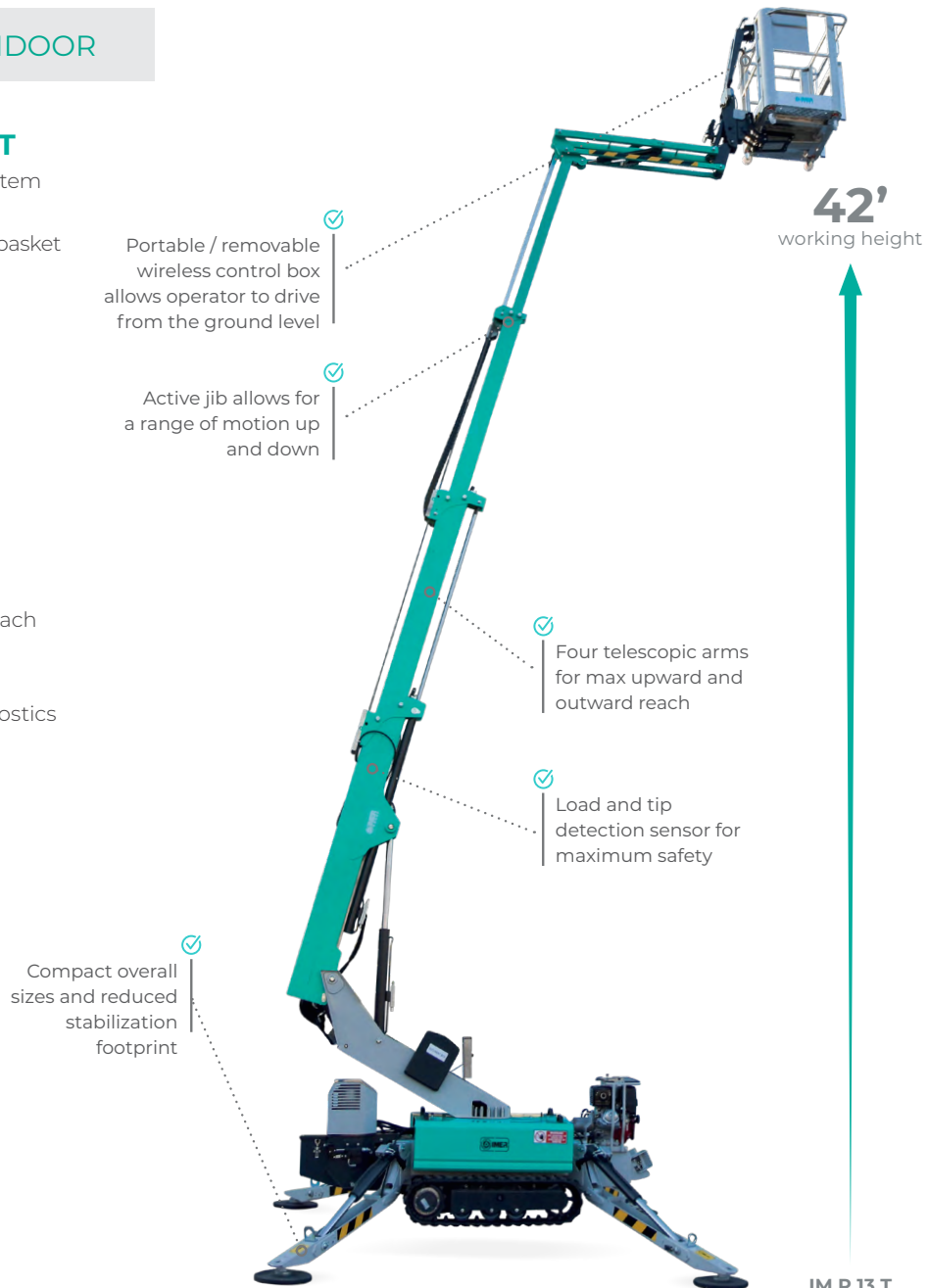

OPTIONAL EQUIPMENT

- Non-marking rubber tracks
- Working light in the platform basket
- 12 V emergency pump
- 120 V desktop remote charge
- Sliding, oversized outrigger shoes
- Oversized outrigger pads
- Double speed traction
- Aluminum basket (2' 11-1/2" x 2' 5")
- Aluminum basket (4' 7" x 2' 3-1/2")
- IMERVIEW GPS Remote Monitor System

IM R 13		
Model #	1128728	
Working height	42'	13 m
Platform height	36'	11 m
Side outreach (weight in basket)	17' / 510 lbs. - 20' 6" / 308 lbs.	5.25 m / 320 kg - 6.3m / 140 kg
Rotation (non-continuous)	355°	
Basket dimensions	51" x 28" x 43"	1300 x 750 x 1100 mm
Transport length (without basket)	12' 4" (9' 8")	3780 mm (3000 mm)
Transport width (without basket)	4' 3" (2' 6")	1300 mm (790 mm)
Height in stowed position (w/ stabilizers)	6' 6 3/4"	2000 mm
Overall outrigger footprint	8' 8" / 9' 2"	2700 x 2800 mm
Driving speed	.93 mph	1.5 km/h
Gradeability	30%	
Platform capacity	510 lbs.	230 kgs
Aux. Electric motor	120 V / 1.5 hp	120 V / 1.125 kW
Honda GX390	13 hp	9.7 kW
Machine weight	3410 lbs.	1550 kg



Thermal-magnetic switch panel and power line inlet.



Easily attach or remove the basket with the one-pin mounting system.



Rugged engine guard for improved protection.

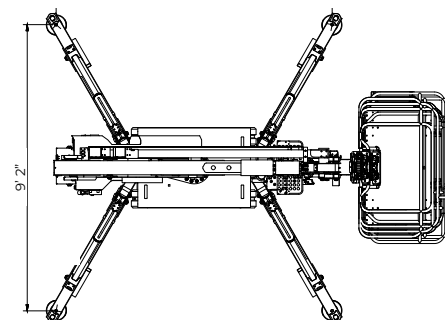
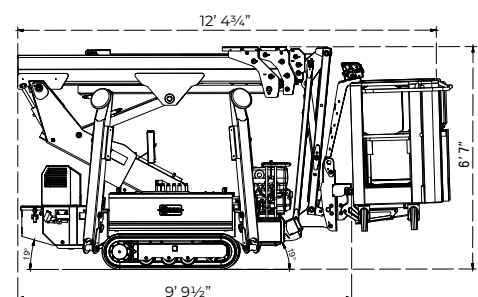
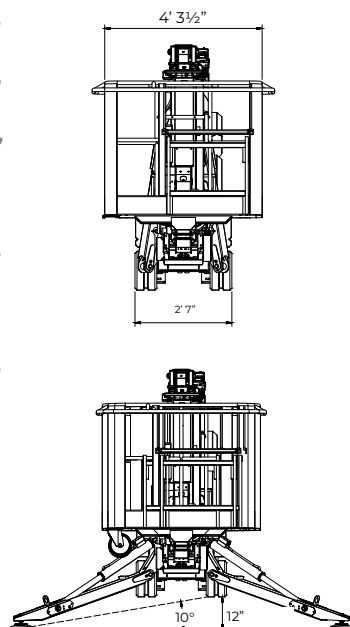
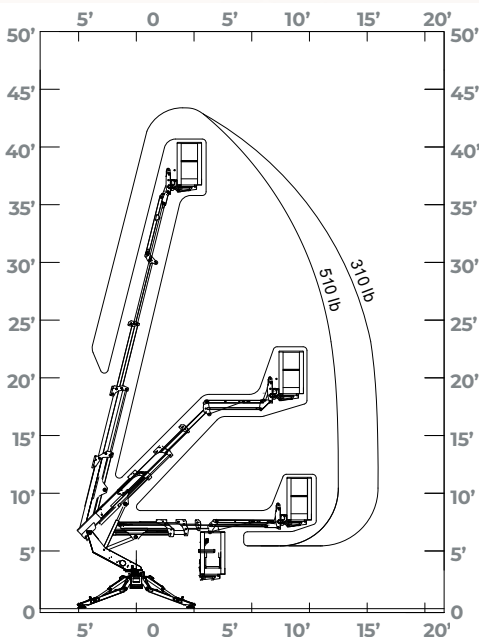

IMERVIEW TELEMATICS

IMER SOLUTIONS

IMER has developed **IMERVIEW** with the aim of making it possible to control various aspects of the machines remotely. **IMERVIEW** gives the ability to give the parameters, functionality and statistics of the machine.

IMERVIEW is a kit which can be combined with the machines of the **ACCESS, EQUIPMENT** and **CONCRETE** Divisions.

FEATURES AND BENEFITS OF THE SYSTEM

**SIMULTANEOUS
REMOTE CONTROL
OF THE MACHINES
AND FLEET**



**MACHINE
PARAMETER
SETTING**



**INTERACTION
WITH IOT DEVICES
AND SYSTEMS**



**SCHEDULED
MAINTENANCE**



**REAL-TIME DISPLAY
OF MACHINE
PARAMETERS**



**DIAGNOSIS OF
MACHINE PROBLEMS**

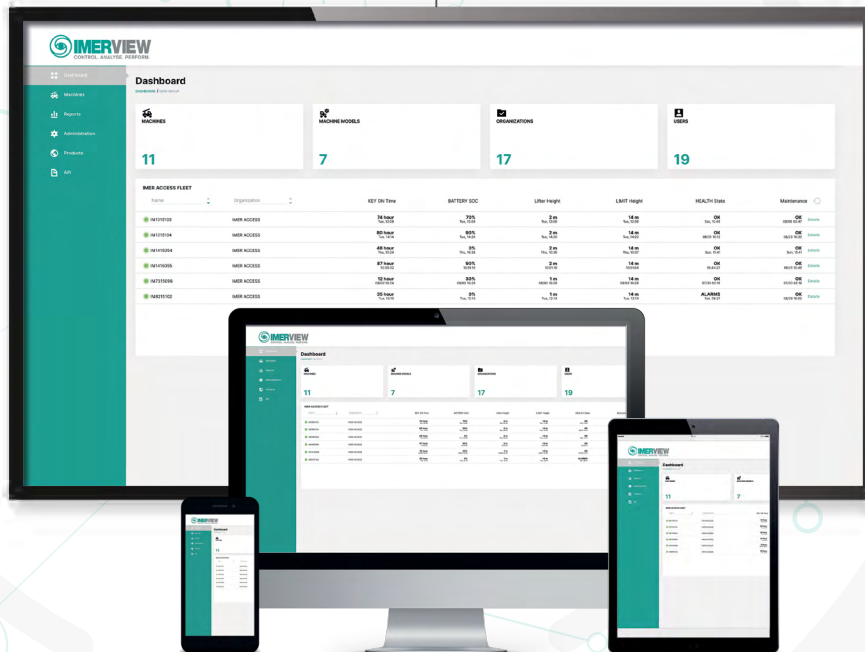

**REPORTS FOR
ACCOUNTING
INFORMATION**



**MACHINE
PARAMETERS
CHECK**



**MACHINE
GEOLOCATION
AND TRACKING**



**GEO FENCING LIMITATION
OF MACHINE
WORKING AREA**



**TIME FENCING SETTING
OF MACHINE
WORKING TIMES**

Get to the IMERVIEW portal:

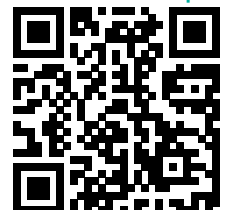

TOGETHER WE BUILD

EXTENDED WARRANTY AVAILABLE

IMER offers extended warranties on all of its products, up to an additional 5 years after the 1 year factory warranty ends. For more information, please reach out to your local sales representative or to IMER USA directly.

IMER GROUP SOLUTIONS

We build machines and equipment that let construction site professionals work with less effort, greater safety, and greater performance.

From batching to cutting, from concrete transport to plaster spraying, from lifting people to earthmoving, we are building many different product lines united under the IMER Group brand with the goal to be the foremost specialists in each of our product lines. We have the expertise to help you select the right products for your business.

Let's build something together!

IMER EQUIPMENT DIVISION



IMER ACCESS DIVISION

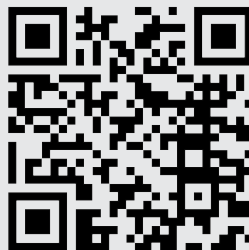

IMER EARTH MOVING DIVISION

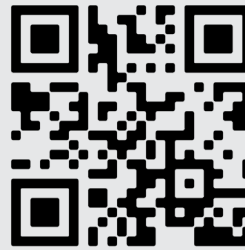

IMER CONCRETE DIVISION

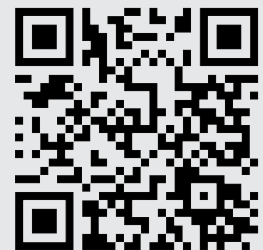



TOLL FREE: 800.275.5463
WWW.IMERUSA.COM



IMER USA, Inc.
423 Bank Street, Suite 180
Southlake, TX 76092
Tel. (800) 275-5463
orders@imerusa.com
www.imerusa.com

IMER Group | USA reserves the right to change the information contained herein without prior notice when they consider it justified. The data and dimensions are therefore not to be considered as binding. The illustrations may include accessories and therefore they could be slightly different from the standard versions of the equipment.

© Copyright by IMER Group | USA