

IM R 19

ATRIUM LIFT SINGLE ARTICULATED

OUTDOOR AND INDOOR USE

STANDARD EQUIPMENT

- Automatic outrigger leveling system
- 355° rotation (non-continuous)
- Hydraulic basket rotation - 124°
- 120V, 15 amp electric motor for indoor use
- Air / Water outlet in the platform basket
- 120V AC power to platform
- Removable wireless control box
- Tether for wired connectivity
- Max 510 lbs in basket (two person capacity)
- Three travel speeds
- Emergency hand pump
- Cylinder holding valve
- Hour meter
- Load and tip detection sensor
- Load cell
- Hydraulic jib
- Rubber tracks
- Remote battery charger
- Removable basket with 1 pin detach
- Overload sensor
- 120V battery charger
- Honda iGX390 engine
- Hydraulically adjustable track width
- Proportional controls with diagnostics

62'
working height

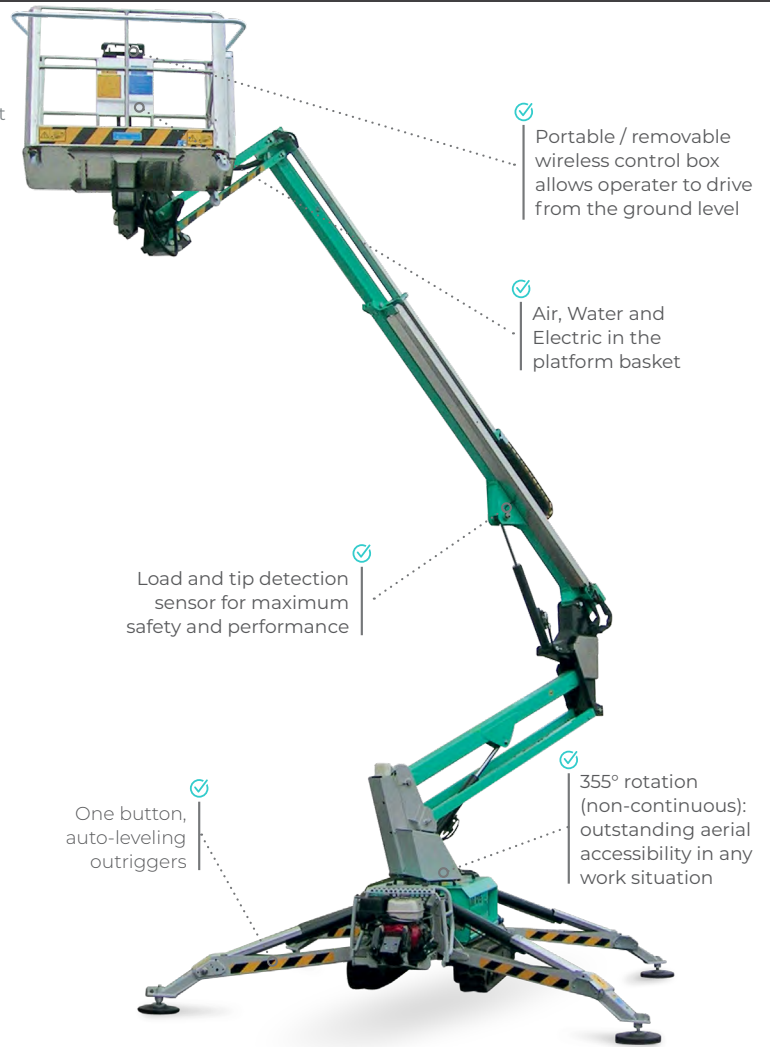

IM R 19

OPTIONAL EQUIPMENT

- Non-marking rubber tracks
- Working light in the platform basket
- 12 V emergency pump
- 120 V desktop remote charge
- Sliding, oversized outrigger shoes
- Oversized outrigger pads
- Double speed traction
- Aluminium basket (2' 11-1/2" x 2' 5")
- Aluminium basket (4' 7" x 2' 3-1/2")
- IMERVIEW GPS Remote Monitor System
- Lithium option
- Yanmar L100N diesel engine

IM R 19

Model # (Lithium)	1128770 (1128772)	
Working height	62'	19 m
Platform height	56'	17 m
Side outreach (weight in basket)	32' / 176 - 28' / 310 - 23' / 510 ft / lb	9.75 / 80 - 8.5 / 120 - 7 / 227 m / kg
Rotation (non-continuous)	355°	
Basket dimensions	57" x 28" x 43"	1448 x 711 x 1092 mm
Basket rotation	124°	
Transport length (without basket)	17' 5" / 15' 2"	5308 / 4622 mm
Transport width (without basket)	Max 3' 6" / Min 2' 7"	Max 1066 / Min 787 mm
Height in stowed position (w/ stabilizers in position)	Min 6' 6" / Max 6' 11"	Min 1981 / Max 2108 mm
Overall outrigger footprint	10' 10" x 10' 11"	3302 x 3327 mm
Stabilizer load	3930 psf	1750 daN
Driving speed	0 - 1.25 mph	0 - 2 km / h
Gradeability	32%	
Electric pump	120 V / 1.5 HP	120 V / 1.125 kW
Max. hydraulic pressure	3190 psi	220 bar
Battery	12V	
Battery charger (Lithium)	12 V / (48 V)	
Honda GX390	13 hp	9.7 kW
Diesel L100N (optional)	8.9 hp	6.6 kW
Machine weight (Lithium)	5370 (5445) lb	2435 (2470) kg

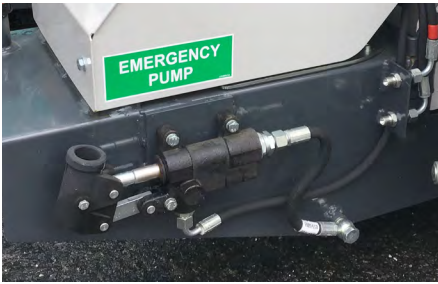

Standard emergency hand pump with ease of access and operation.



Compact jib assembly hosting both the load sensor and basket rotation system.



Hydraulically adjust the track width for added stability and traction.



Compact width allows access in narrow, hard to reach places

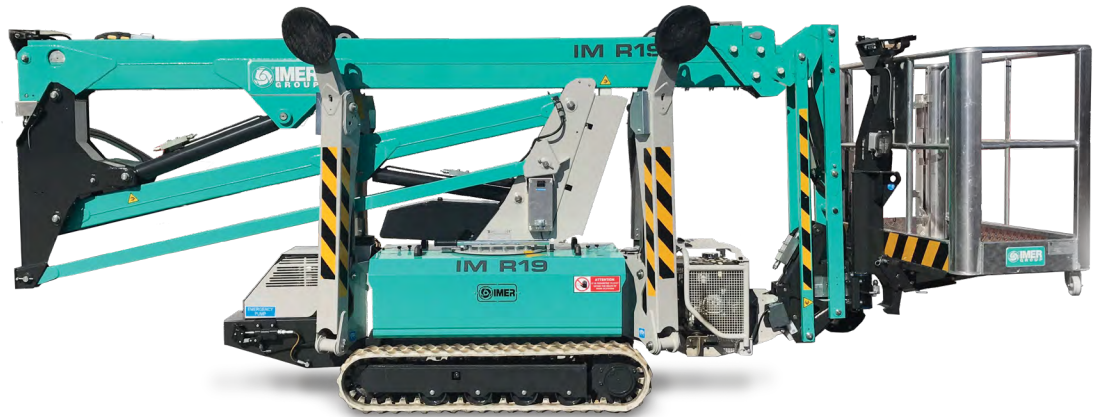

Easy access both outdoor and indoor. Non-marking tracks for indoor use

